

IT.	DESCRIPTION	MATERIAL
1	RIVET	CARBON STEEL
2	NAME PLATE	ALUMINUM
3	BONNET	A105N
4	B/B BOLTS	A193-B7
5	SPRING	* 316
6	B/B GASKET	F316L + GRAPHITE
7	DISC	AISI-410
8	INTEGRAL SEAT	+ STELLITE
9	BODY	A105N

* SPRING SUPPLIED UPON REQUEST.

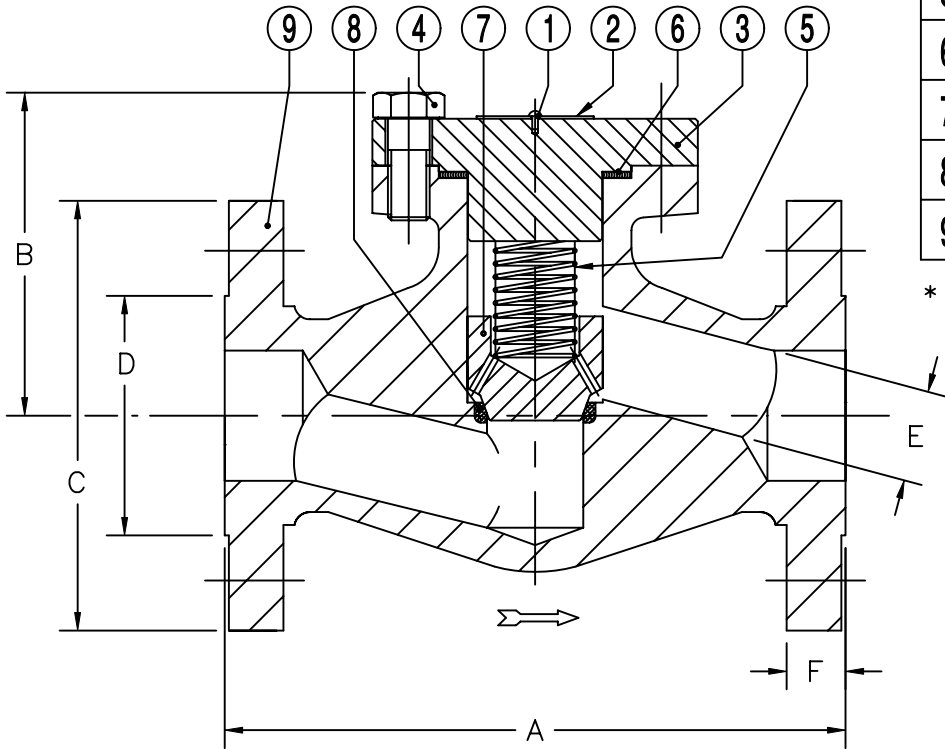

125 - 250 AARH
SERRATED SPIRAL FINISH

VALVE SIZE	1/4	3/8	1/2	3/4	1	1 1/4	1 1/2	2
DIMENSION								
A			4 1/4	4 5/8	5		6 1/2	8
B			2 15/16	2 15/16	3 3/8		4 5/16	4 15/16
C			3 1/2	3 7/8	4 1/4		5	6
D			1 3/8	1 11/16	2		2 7/8	3 5/8
E			.354	.512	.689		1.161	1.378
F			7/16	1/2	5/8		11/16	13/16
ITEM#								
APPROX. WT.			5	6 3/4	10		18 1/2	30 3/4

CUSTOMER:
P.O. NUMBER:
TAG NUMBER:
JOB NUMBER:
BB/TRIM: A105N / 13% CR.

B **BONNEY FORGE**
U.S. ROUTE 522 SOUTH
P.O. BOX 330
MOUNT UNION, PA 17066



**PISTON CHECK VALVES
INTEGRAL RF FLANGE ENDS
CLASS 150# - REDUCED BORE**

REV	DESCRIPTION	DATE	BY	DR.	DATE	DRAWING NO.	REV.
	REVISIONS			BSG	12-14-98	L1-41-RF	0
				JW	NONE		