

IT.	DESCRIPTION	MATERIAL
1	RIVET	CARBON STEEL
2	NAME PLATE	ALUMINUM
3	BONNET	A105N
4	B/B BOLTS	A193-B7
5	SPRING	SEE NOTE
6	B/B GASKET	F316L + GRAPHITE
7	DISC	AISI-410
8	INTEGRAL SEAT	+ STELLITE
9	BODY	A105N

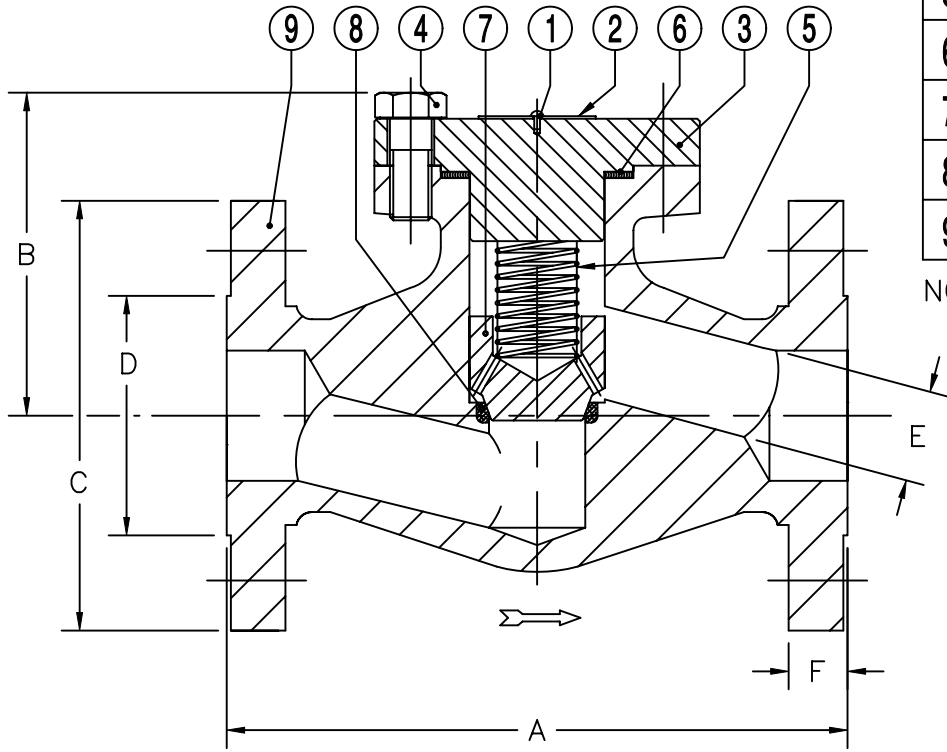

NOTE: THE SPRING WILL BE SUPPLIED ONLY ON REQUEST.

125 - 250 AARH  
SERRATED SPIRAL FINISH

VALVE SIZE	1/4	3/8	1/2	3/4	1	1 1/4	1 1/2	2
<b>DIMENSION</b>								
A			6	7	8		9	10 1/2
B			2 15/16	3 1/8	3 7/16		4 1/2	5 1/8
C			3 3/4	4 5/8	4 7/8		6 1/8	6 1/2
D			1 3/8	1 11/16	2		2 7/8	3 5/8
E			.354	.512	.689		1.161	1.378
F			9/16	5/8	11/16		13/16	7/8
ITEM#								
APPROX. WT.			7 1/2	11 3/4	16 1/2		30 3/4	42

CUSTOMER:  
P.O. NUMBER:  
TAG NUMBER:  
JOB NUMBER:  
BB/TRIM: A105N/ 13% CR.

**B** BONNEY FORGE  
U.S. ROUTE 522 SOUTH  
P.O. BOX 330  
MOUNT UNION, PA 17066



**PISTON CHECK VALVES  
INTEGRAL RF FLANGE ENDS  
CLASS 300# - REDUCED BORE**

REV	DESCRIPTION	DATE	BY	DR.	DATE	DRAWING NO.	REV.
	REVISIONS			BSG	12-15-98	L3-41-RF	0
				APPD. GW	SCALE NONE		