

IT.	DESCRIPTION	MATERIAL
1	RIVET	CARBON STEEL
2	NAME PLATE	ALUMINUM
3	BONNET	A105N
4	B/B BOLTS	A193-B7
5	SPRING	SEE NOTE
6	B/B GASKET	F316L + GRAPHITE
7	BALL	AISI-420
8	INTEGRAL SEAT	+ STELLITE
9	BODY	A105N

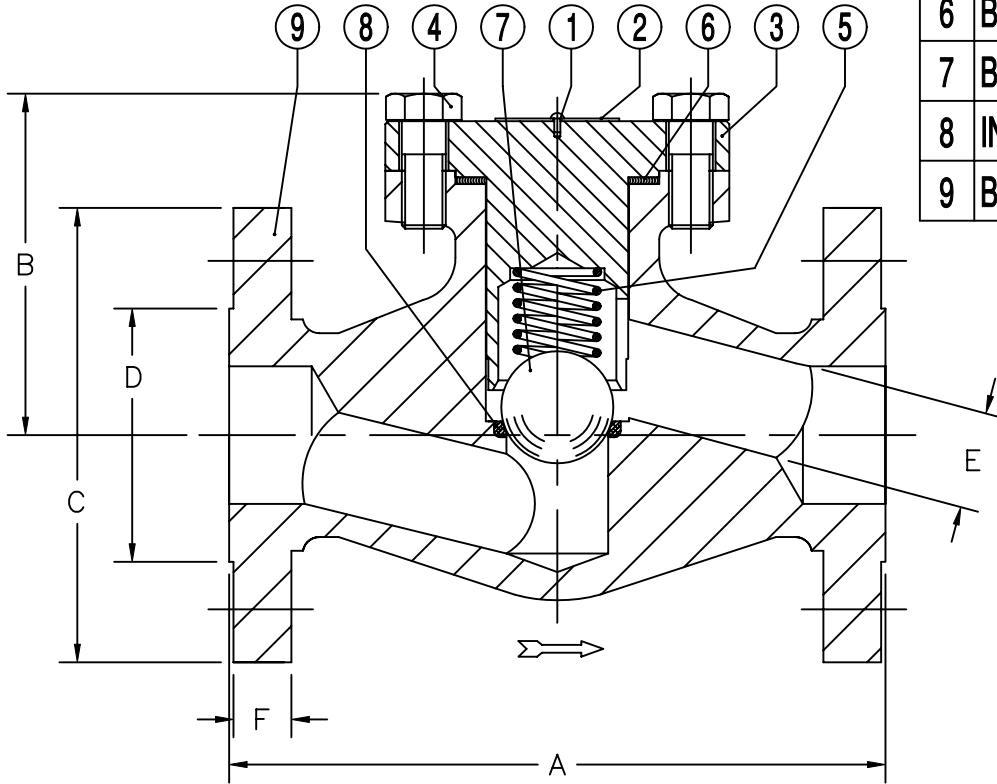

(125-250 AARH)
SERRATED SPIRAL FINISH

VALVE SIZE	1/4	3/8	1/2	3/4	1	1 1/4	1 1/2	2
DIMENSION								
A			6 1/2	7 1/2	8 1/2		9 1/2	11 1/2
B			2 15/16	3 1/4	3 7/16		4 1/2	5 1/8
C			3 3/4	4 5/8	4 7/8		6 1/8	6 1/2
D			1 3/8	1 11/16	2		2 7/8	3 5/8
E			.354	.512	.689		1.161	1.378
F			9/16	5/8	11/16		7/8	1
ITEM#								

CUSTOMER:
P.O. NUMBER:
TAG NUMBER:
JOB NUMBER:
BB/TRIM: A105N / 13% CR.

B **BONNEY FORGE**
U.S. ROUTE 522 SOUTH
P.O. BOX 330
MOUNT UNION, PA 17066



**BALL CHECK VALVES
INTEGRAL RF FLANGE ENDS
CL.600# - REDUCED BORE**

REV	DESCRIPTION	DATE	BY	DR.	DATE	DRAWING NO.	REV.
	REVISIONS			BSG	12-15-98	L6-51-RF	0
				JW	NONE		