

GLOBE

CLASS 100 BRONZE

Screw-In-Bonnet • Inside Screw • Rising Stem
Integral Seat • Solid Wedge Disc

CODE # 01 (AKA)
THREADED

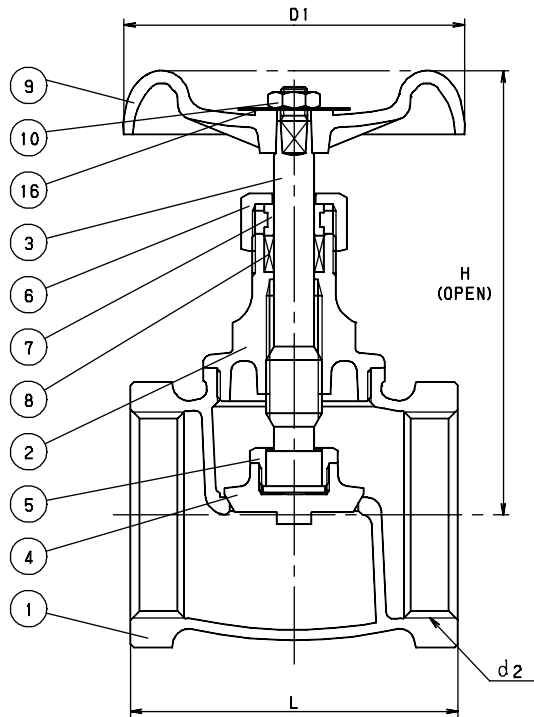

STANDARDS	
END TO END	KITZ
THREADED ENDS	ANSI B1.20.1
DESIGN	KITZ

PRESSURE/TEMPERATURE
100 PSI - SATURATED STEAM TO 338°F - FLUID TO 406°F
150 PSI NON-SHOCK COLD WATER, OIL OR GAS

MATERIAL LIST		
NO.	NAME OF PART	SPECIFICATION
1	BODY	CAST BRONZE (ASTM B584, C84400)
2	BONNET (1/4 - 3) (4)	FORGED BRASS (B283, C37700) CAST BRONZE (B584, C84400)
3	STEM	BRASS (KITZ "K" METAL)
4	DISC (1/4 - 3) (4)	FORGED BRASS (B283, C37700) CAST BRONZE (B584, C84400)
5	LOCK NUT	FORGED BRASS (B124, C37700)
6	PACKING NUT	FORGED BRASS (B283, C37700)
7	GLAND	BRASS ROD (B16)
8	GLAND PACKING	PLASTIC GRAPHITE
9	HAND WHEEL (1/4 - 3) (4)	ZINC DIE-CAST (B86) CAST IRON
10	WHEEL NUT	CARBON STEEL
16	NAME PLATE	ALUMINUM

DIMENSIONS - WEIGHTS - QUANTITIES					
SIZE d2	H	D1	L	APPROX. NET WT.	CARTON QTY
1/4	2.60	1.97	1.57	45	100
3/8	2.64	1.97	1.65	46	100
1/2	2.72	2.17	1.89	51	80
3/4	3.15	2.36	2.09	46	60
1	3.70	2.76	2.48	56	48
1 1/4	4.09	3.15	2.87	55	36
1 1/2	5.00	3.54	3.19	57	25
2	5.79	3.94	3.70	53	16
2 1/2	7.05	4.53	4.53	55	8
3	7.87	5.31	5.16	55	6
4	9.84	7.09	6.73	58	3

BRONZE GLOBE