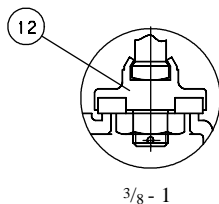
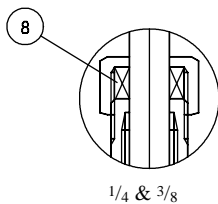
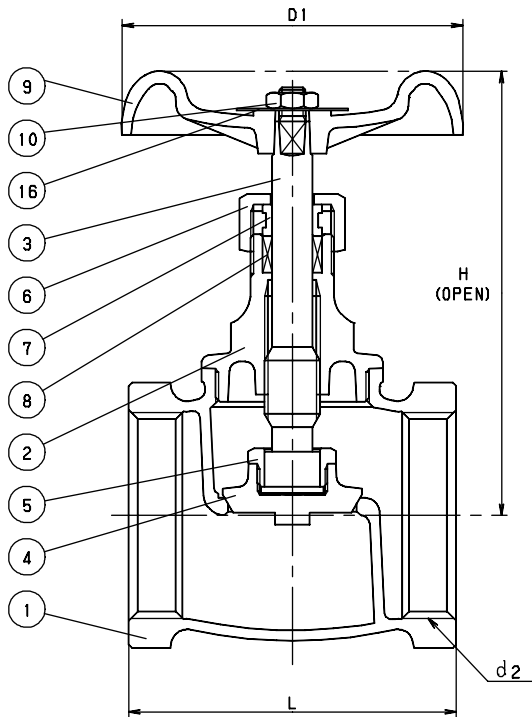

GLOBE**CLASS 125 BRONZE**

Union Bonnet • Inside Screw • Rising Stem
G/F + PTFE Disc

**CODE # 03 (AKG)
THREADED****STANDARDS**

END TO END	KITZ
THREADED ENDS	ANSI B1.20.1
DESIGN	KITZ

PRESSURE/TEMPERATURE

125 PSI - SATURATED STEAM TO 353°F
- FLUID TO 406°F
200 PSI NON-SHOCK COLD WATER, OIL OR GAS

MATERIAL LIST

NO.	NAME OF PART	SPECIFICATION
1	BODY	CAST BRONZE (B584 C84400)
2	BONNET (1/4 - 2) (2 1/2 - 3)	FORGED BRASS (B283 C37700) CAST BRONZE (B584 C84400)
3	STEM	BRASS (KITZ "K" METAL)
4	DISC	G/F + PTFE
5	LOCK NUT (1 1/4 - 3)	FORGED BRASS (B124, C37700)
6	PACKING NUT	FORGED BRASS (B283, C37700)
7	GLAND	BRASS ROD (B16) (1/2 - 3)
8	GLAND PACKING	PLATIC GRAPHITE
9	HAND WHEEL (1/4 - 3/4) (1 - 3)	ZINC DIE-CAST (B86) ALUMINUM DIE-CAST (B85)
10	WHEEL NUT	CARBON STEEL
11	BONNET RING (3/8 - 2) (2 1/2 - 3)	FORGED BRASS (B283, C37700) CAST BRONZE (B584, C84400)
12	DISC HOLDER	FORGED BRASS (B283, C37700)
13	DISC NUT (1/4 - 1) (1 1/4 - 3)	BRASS ROD (B16) FORGED BRASS (B283, C37700)
14	SPLIT PIN (3/8 - 3)	COPPER
16	NAME PLATE	ALUMINUM

DIMENSIONS - WEIGHTS - QUANTITIES

SIZE d2	H	D1	L	APPROX. NET WT.	CARTON QTY
1/4	2.68	1.97	1.85	59	120
3/8	3.46	2.17	2.09	64	72
1/2	3.94	2.36	2.24	61	60
3/4	4.33	2.76	2.60	59	40
1	4.72	3.15	2.99	65	30
1 1/4	5.51	3.54	3.46	59	20
1 1/2	6.14	3.94	3.94	56	12
2	7.28	4.53	4.72	61	8
2 1/2	8.27	5.31	5.79	88	6
3	9.02	6.10	6.38	65	4