

ANGLE GLOBE

CLASS 150 BRONZE

Screw-In-Bonnet • Inside Screw • Rising Stem
Bronze Disc

CODE # 38 (AKCA)
THREADED

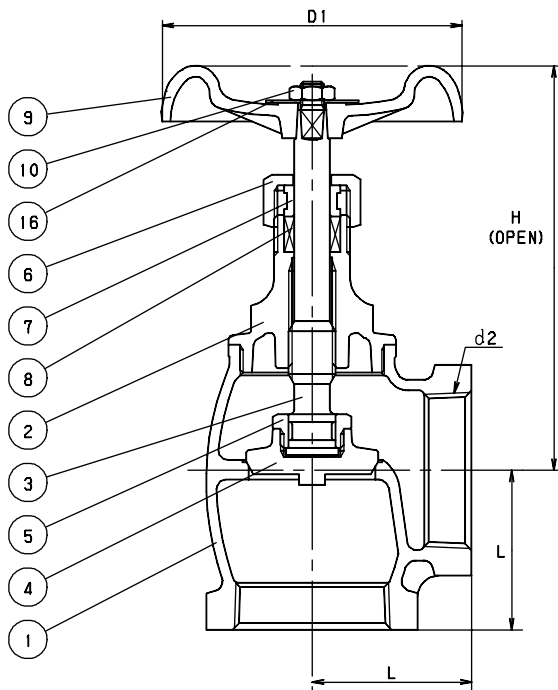

STANDARDS

END TO END	KITZ
THREADED ENDS	ANSI B1.20.1
DESIGN	KITZ

PRESSURE/TEMPERATURE

150 PSI - SATURATED STEAM TO 366°F
- FLUID TO 406°F
300 PSI NON-SHOCK COLD WATER, OIL OR GAS

MATERIAL LIST

NO.	NAME OF PART	SPECIFICATION
1	BODY	CAST BRONZE (B584, C84400)
2	BONNET (1/4 - 2 1/2) (3)	FORGED BRASS (B283, C37700) CAST BRONZE (B584, C84400)
3	STEM	BRASS (KITZ "K" METAL)
4	DISC	CAST BRONZE (B584, C84400)
5	LOCK NUT	FORGED BRASS (B124, C37700)
6	PACKING NUT	FORGED BRASS (B283, C37700)
7	GLAND	BRASS ROD (B16)
8	GLAND PACKING	PLASTIC GRAPHITE
9	HAND WHEEL (1/4 - 3/4) (1 - 3)	ZINC DIE-CAST (B86) ALUMINUM DIE-CAST (B85)
10	WHEEL NUT	CARBON STEEL
16	NAME PLATE	ALUMINUM

DIMENSIONS - WEIGHTS - QUANTITIES

d2 SIZE	H	D1	L	APPROX. NET WT.	CARTON QTY
1/4	2.60	1.97	.83	35	80
3/8	2.68	1.97	.95	41	80
1/2	3.11	2.36	1.10	35	60
3/4	3.66	2.76	1.34	55	56
1	4.09	3.15	1.57	51	36
1 1/4	5.00	3.54	1.85	57	25
1 1/2	5.71	3.94	2.05	57	16
2	6.85	4.53	2.40	49	8
2 1/2	7.83	5.31	2.91	51	6
3	8.46	6.10	3.35	46	4