

GATE

CLASS 125 BRONZE

Screw-In-Bonnet • Non-Rising Stem
Solid Wedge Disc

CODE # 40 (AK125E) THREADED

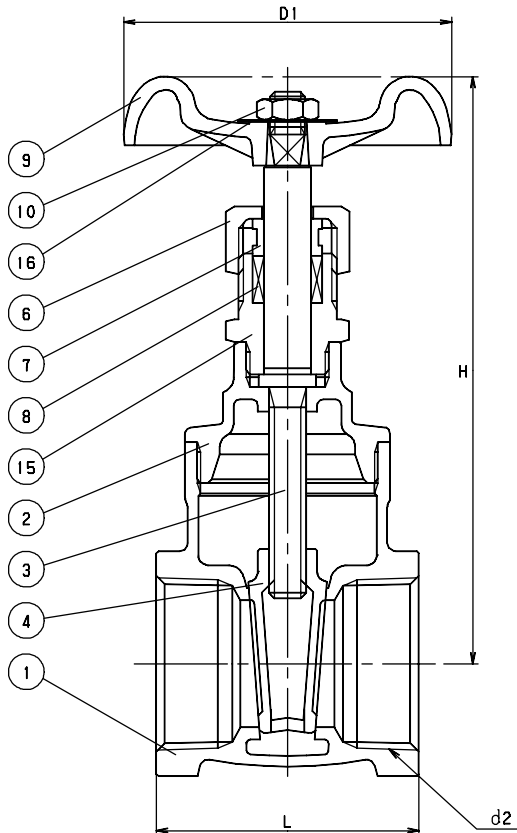

CODE # 41 (C125E) SOLDER*

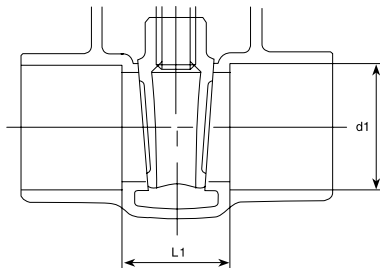

STANDARDS

END TO END	KITZ
THREADED ENDS	ANSI B1.20.1
SOLDER JOINT ENDS	ANSI B16.18
DESIGN	MSS SP-80, TYPE 1
MILITARY	MSS SP-80, TYPE 1

PRESSURE/TEMPERATURE

125 PSI - SATURATED STEAM TO 353°F
- FLUID TO 406°F
200 PSI NON-SHOCK COLD WATER, OIL OR GAS

MATERIAL LIST

NO.	NAME OF PART	SPECIFICATION
1	BODY	CAST BRONZE (ASTM B62)
2	BONNET	CAST BRONZE (ASTM B62)
3	STEM	CAST BRONZE (ASTM B62)
4	DISC	CAST BRONZE (ASTM B62)
6	PACKING NUT	FORGED BRASS (B283, C37700)
7	GLAND	BRASS ROD (B16)
8	GLAND PACKING	PLASTIC GRAPHITE
9	HAND WHEEL (3/8 - 1) (1 1/4 - 2)	ZINC DIE-CAST (B86) ALUMINUM DIE-CAST (B85)
10	WHEEL NUT	BRASS ROD (B16)
15	STUFFIN BOX	BRASS ROD (B16)
16	NAME PLATE	ALUMINUM

DIMENSIONS - WEIGHTS - QUANTITIES

d2 SIZE	H	D1	L	L1	d1		APPROX. NET WT.	CARTON QTY
					Max.	Min.		
3/8	3.89	1.97	1.69	.78	.506	.502	67	96
1/2	3.66	2.17	1.93	.81	.631	.627	61	72
3/4	4.33	2.36	2.09	.86	.881	.877	63	54
1	4.96	2.76	2.40	.98	1.132	1.128	62	36
1 1/4	5.71	3.15	2.52	1.17	1.382	1.378	58	24
1 1/2	6.69	3.54	2.68	1.28	1.633	1.628	60	18
2	7.44	3.94	2.91	1.57	2.133	2.128	57	12

*SEE PRESSURE/TEMPERATURE LIMITATIONS
FOR SOLDER JOINT VALVES - P. BIV-50.