

# FORGED BRASS BALL VALVE

## THREE WAY

Two Piece Body • Maintenance Free Double O-Ring Stem Seals • L-Port Design  
 Chrome Plated Ball • PTFE Seats • Blowout Proof Stem

FORGED BRASS BALL VALVES

### CODE # 54 (AKTN)

1/4" - 3/8" / 2 1/2" - 3"  
**THREADED**

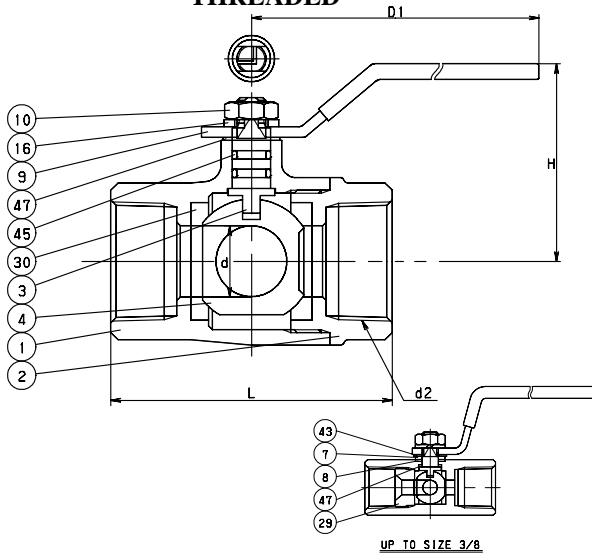

### CODE # 55 (CTN)

1 1/4" - 2"  
**SOLDER\***

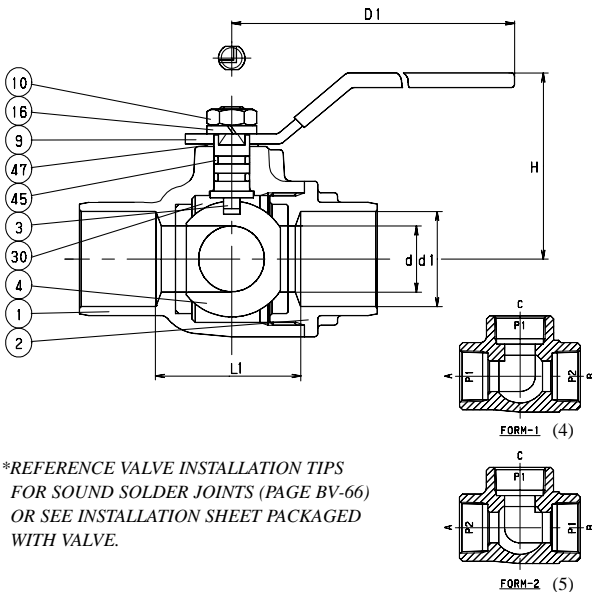

\*REFERENCE VALVE INSTALLATION TIPS  
 FOR SOUND SOLDER JOINTS (PAGE BV-66)  
 OR SEE INSTALLATION SHEET PACKAGED  
 WITH VALVE.

### SPECIFICATION

Approved valve shall have three way two piece forged brass body, blowout proof stem, PTFE seats, maintenance free double o-ring stem seals, chrome plated ball, and L-port design. Valves shall be pressure rated to 150 PSI @ 300°F/400 WOG.

KITZ Code No. 54 (AKTN) Threaded Ends  
 55 (CTN) Soldered Ends

### STANDARDS

END TO END	KITZ
THREADED ENDS	ANSI B1.20.1
SOLDER JOINT ENDS	ANSI B16.18
WALL THICKNESS	KITZ

### PRESSURE/TEMPERATURE

150 PSI @ 300° F  
 400 PSI NON-SHOCK COLD WATER, OIL OR GAS

NOTE: PRESSURE/TEMPERATURE CHART - PAGE BV-29

### MATERIAL LIST

NO.	NAME OF PART	SPECIFICATION
1	BODY (2 1/4"-3")	FORGED BRASS (B283, C37700) CAST BRONZE
2	BODY CAP	FORGED BRASS (B283, C37700)
3	STEM	(1) SPECIAL BRASS (KITZ, K-METAL)
4	BALL	(2) FORGED BRASS (B283, C37700)
7	GLAND	STAINLESS STEEL (A276, TYPE 430)
8	GLAND PACKING	G/F PTFE
9	HANDLE	(3) STAINLESS STEEL
10	HANDLE NUT	CARBON STEEL
16	WASHER	CARBON STEEL
29	INSERT	FORGED BRASS (B124, C37700)
30	BALL SEAT	PTFE
43	SPRING	STAINLESS STEEL (A276, TYPE 304)
45	O-RINGS	FPM
47	THRUST WASHER(1/4"-3/8") (1 1/4"-3")	REINFORCED PTFE POM

NOTES: (1) PROPRIETARY DEZINCIFICATION RESISTANT MATERIAL  
 (2) CR. PLATING  
 (3) WITH PLASTIC COVERING  
 (4) FLOW IS FACILITATED BETWEEN "A" & "C" AFTER EXTENDED USE, PORT "B" MAY LEAK SLIGHTLY TO PORT "A" & "C" IF PRESSURE IN P2 IS HIGHER THAN P1.  
 (5) FLOW IS FACILITATED BETWEEN "C" & "B" AFTER EXTENDED USE, PORT "A" MAY LEAK SLIGHTLY TO PORT "B" & "C", IF PRESSURE IN P2 IS HIGHER THAN P1

### DIMENSIONS - WEIGHTS - QUANTITIES

d2 SIZE	d	H	D1	L	L1	d1	APPROX. CARTON NET WT.	QTY
1/4	.18	1.18	2.36	1.57	.79	.381 .377	22	120
3/8	.27	1.77	3.15	1.81	.91	.506 .502	44	120
1 1/4	.98	2.36	5.12	3.90	1.99	1.132 1.128	67	24
1 1/2	1.26	2.56	5.12	4.49	2.32	1.382 1.378	62	16
2	1.57	2.95	5.90	5.35	2.81	1.633 1.628	72	12
2 1/2	1.97	3.58	7.87	5.43	2.72	2.133 2.128	71	6
3	2.56	4.13	11.81	6.54	3.27	2.633 2.628	74	4