

FORGED BRASS BALL VALVE

MAINTENANCE FREE DOUBLE O-RING STEM SEALS

Two Piece Body • Full Port • Chrome Plated Ball

Blowout Proof Stem (Ni Plated) • PTFE Seats

CSA (US/C) • UL • FM**

CODE # 58W THREADED

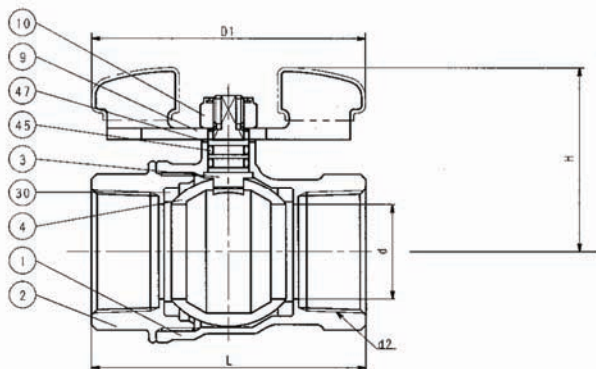

CODE # 59W SOLDER*

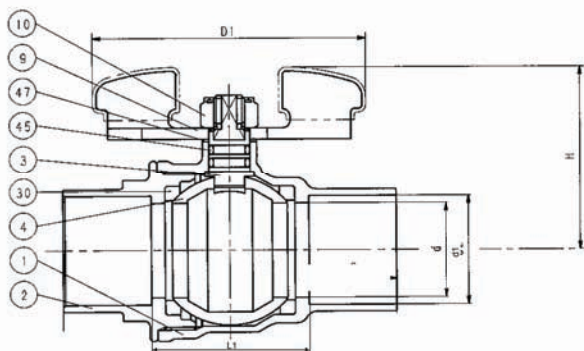

*REFERENCE VALVE INSTALLATION TIPS FOR SOUND SOLDER JOINTS (PAGE BV-66) OR SEE INSTALLATION SHEET PACKAGED WITH VALVE.

SPECIFICATION

Approved valve shall have two piece forged brass body, blowout proof stem (Ni Plated), PTFE seats, maintenance free double o-ring stem seals, chrome plated ball and full port design with wing handle. Valves shall be pressure rated to 150 WSP/600 WOG and conform to MSS-SP 110 and CSA, UL & FM.

KITZ Code No. 58W Threaded Ends
59W Solder Ends

STANDARDS

END TO END	KITZ
THREADED ENDS	ANSI B1.20.1
SOLDER JOINT ENDS	ANSI B16.18
WALL THICKNESS	KITZ
CONFORMS TO MSS-SP 110 - REPLACES US. FED. SPEC. WWW-V-35B, TYPE II, CLASS A, STYLE 3	

PRESSURE/TEMPERATURE

150 PSI SATURATED STEAM TO 366°F
600 PSI - NON-SHOCK COLD WATER, OIL OR GAS

NOTE: PRESSURE/TEMPERATURE CHART - PAGE BV-29

MATERIAL LIST

NO.	NAME OF PART	SPECIFICATION
1	BODY	FORGED BRASS (B283, C37700)
2	BODY CAP	FORGED BRASS (B283, C37700)
3	STEM	(1) BRASS ROD (B16)
4	BALL	(2) FORGED BRASS (B283, C37700) STRAIGHT OR HOLLOW BALL
9	HANDLE	(3) CARBON STEEL
10	HANDLE NUT	CARBON STEEL
30	BALL SEATS	PTFE
45	O-RINGS	FPM
47	THRUST WASHER	PBT

NOTES: (1) Ni PLATING
(2) CR. PLATING
(3) ELECTROPLATED ZINC WITH PLASTIC COVERING

DIMENSIONS - WEIGHTS - QUANTITIES

d2 SIZE	d	H	D1	L	L1	d1 Max. Min.	APPROX. CARTON NET WT. QTY
1/4	.39	1.32	2.17	1.65	1.11	- -	29 120
3/8	.39	1.32	2.17	1.65	1.05	.506 .502	29 120
1/2	.59	1.55	3.76	2.08	1.13	.631 .627	29 96
3/4	.79	1.70	3.15	2.36	1.37	.881 .877	45 60
1	.98	2.06	4.33	2.83	1.64	1.132 1.128	60 36
1 1/4	1.26	2.27	4.33	3.31	2.00	1.382 1.378	68 24
1 1/2	1.57	2.88	5.90	3.62	2.35	1.633 1.628	50 16
2	1.97	3.17	5.90	4.33	2.83	2.133 2.128	71 16

**CSA (US/C):
ASME B16.33 - 125G
AGA 3-88 - 2/5G
CGA 9.1 M97/ANSI 21.15-1997 - .5G
CGA 3.16-M88 - 125G
CGA CR 91-002
CGA 9.2 M-88 - .5G
UL-258 - 175 WWP (Fire Protection Trim Valves)
FM-1140 - 175 WWP (Fire Protection Systems)

