

A Series Forged Brass CSA Gas Ball Valves

315

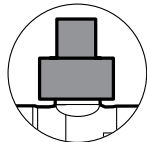

Forged 1 piece construction
ASME B1.20.1 NPT Ends
Smooth, quarter turn operation
May be used with water 400 PSI
Seals at high and low pressure -
ideal for testing installations
For use with natural, manufactured,
liquified petroleum &
LP gas-air mixtures to
ANSI Z21.15 / CSA 9.1 (1/2 PSIG)
ASME B16.44, CGA-CR91-002 (2 & 5 PSIG)
-40° to 125°F

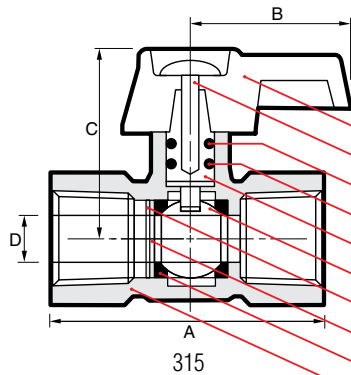

315 SH
Optional; Square Operating Nut

NAME / MATERIAL	
1.	Handle / Aluminum ASTM B85-A03840
2.	Screw / Steel ASTM 36 Zinc Plated
3.	Stem-O-Ring / NBR 70SH
4.	Stem-O-Ring / Viton
5.	Stem / Brass ASTM B124-C37700
6.	Ball / Chromium Plated Brass ASTM B124-C37700
7.	Retainer Clip / Steel DIN17222
8.	Seat Washer / Brass ASTM B124-C37700
9.	Seat O-Ring / NBR 70SH
10.	Body / Brass ASTM B283-C37700
11.	Square Nut / Al. ASTM B85-A03840

D I M E N S I O N S				
size (in.)	1/2	3/4	1/2 SH	3/4 SH
A	54.0	57.5	54.0	57.5
mm/in	2.13	2.24	2.13	2.24
B	38.0	37.8	-	-
mm/in	1.48	1.47	-	-
C	32.0	34.5	36.0	38.5
mm/in	1.24	1.35	1.40	1.50
D	10.0	14.0	10.0	14.0
mm/in	0.39	0.55	0.39	0.55
Weight	0.4	0.5	0.4	0.5
lb/kg	0.50	0.62	0.50	0.62