

# A Series Forged Brass CSA Gas Ball Valves

## 327

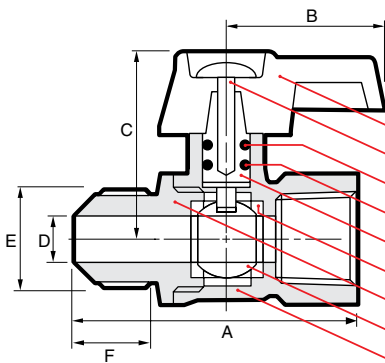

Forged 2 piece construction  
ASME B1.20.1 NPT end x Flare  
Smooth, quarter turn operation  
May be used with water 400 PSI  
Seals at high and low pressure -  
ideal for testing installations  
For use with natural, manufactured,  
liquefied petroleum &  
LP gas-air mixtures to  
ANSI Z21.15, CSA 9.1 (1/2 PSIG)  
ASME-B16.44,  
CGA CR91-002 (2 & 5 PSIG)  
-40° to 125°F



### N A M E / M A T E R I A L

1. Handle / Aluminum ASTM B85-A03840
2. Screw / Steel ASTM 36 Zinc Plated
3. Stem-O-Ring / NBR 70SH
4. Stem-O-Ring / Viton
5. Stem / Brass ASTM B124-C37700
6. Seats / PTFE
7. Body-Cap / Brass ASTM B283-C37700
8. Ball / Chromium Plated Brass ASTM B124-37700
9. Body / Brass ASTM B283-C37700

### D I M E N S I O N S

size (in.)	1/2	1/2	3/4
A	57.7	61.0	70.8
mm/in	2.27	2.40	2.79
B	37.8	37.8	37.8
mm/in	1.49	1.49	1.49
C	32.3	32.3	36.9
mm/in	1.27	1.27	1.45
D	7.14	10.3	12.7
mm/in	0.28	0.41	0.50
E size	5/8 - 18 UNF	3/4 - 16 UNF	15/16 - 16 UNF
F	15.7	19.0	22.4
mm/in	0.62	0.75	0.88
Weight	0.14	0.15	0.24
kg/lbs	0.306	0.322	0.520