



M. A. Stewart & Sons Ltd.
VALVES AND FITTINGS

B Series Forged Brass PEX Valve

B-1PEX

Mini Ball valve for PEX tubing
CSA B-137.5
Large port
Two piece body
Blowout-proof stem
Chrome plated ball
Class 150 WSP, 400 WOG

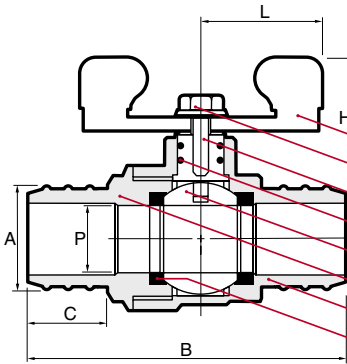

NAME / MATERIAL

1. Handle / Steel ASTM A36
2. Handle Screw / Steel ASTM A36
3. Stem / Brass ASTM B124-C37700
4. O Ring / NBR 70 SH Rubber
5. Ball / Chrome Plated Brass Alloy
6. Cap / Brass B283-C37700
7. Body / Brass B283-C37700
8. Seat / PTFE

D I M E N S I O N S								
size (in.)	A	B	C	H	L	P	CV	Weight
	mm/in	mm/in	mm/in	mm/in	mm/in	mm/in		lb/kg
1/2	12.0	60.0	16.0	40.0	26.0	10.0	7	0.55
	0.47	2.36	0.63	1.57	1.02	0.39		0.250
3/4	16.9	64.0	16.0	41.8	26.0	12.7	13	0.79
	0.67	2.52	0.63	1.65	1.02	0.50		0.360
1	21.7	80.0	21.0	47.0	31.0	18.0	27	1.28
	0.85	3.15	0.83	1.85	1.22	0.71		0.580

B-1D PEX

Mini Ball valve with drain for PEX tubing
CSA B-137.5
Large port
Two piece body
Blowout-proof stem
Chrome plated ball
Class 150 WSP, 400 WOG

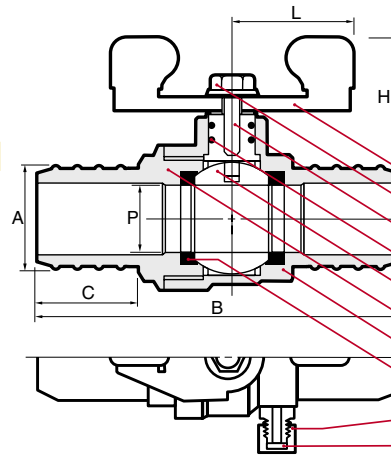

NAME / MATERIAL

1. Handle / Steel ASTM A36
2. Lever Screw / Steel ASTM A36
3. Stem / Brass ASTM B124-C37700
4. O Ring / NBR 70 SH Rubber
5. Ball / Chrome Plated Brass Alloy
6. Cap / Brass B283-C37700
7. Body / Brass B283-C37700
8. Seat / PTFE
9. Plug / Brass ASTM B124-C37700
10. Cap Washer / NBR NSF Approved

D I M E N S I O N S								
size (in.)	A	B	C	H	L	P	CV	Weight
	mm/in	mm/in	mm/in	mm/in	mm/in	mm/in		lb/kg
1/2	12.0	68.0	16.0	40.0	26.0	10.0	7	0.55
	0.47	2.78	0.63	1.57	1.02	0.39		0.250
3/4	16.9	71.0	16.0	41.8	26.0	12.7	13	0.79
	0.67	2.80	0.63	1.65	1.02	0.50		0.360
1	21.7	87.5	21.0	47.0	31.0	18.0	27	1.28
	0.85	3.44	0.83	1.85	1.22	0.71		0.580

