

B Series Forged Brass Ball Valves

B-1F

- Forged 2 piece construction
- Full port (1/2" to 2")
- ASME B1.20.1 NPT ends
- Blowout-proof stem, Chrome plated ball
- Adjustable packing gland
- Secondary o-ring stem seal
- Class 150 WSP
- 1/2" to 2": 600 WOG (**B-1F**)
- 2 1/2" to 4": 400 WOG (**B-1**)
- Reduced port & NPT end to MFR STD

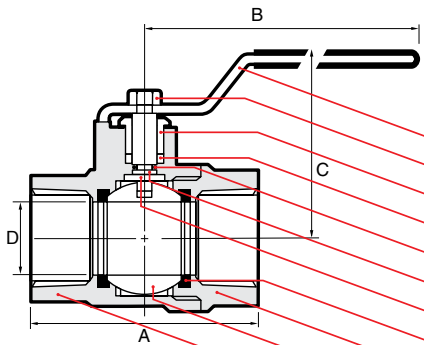

| P A R T / M A T E R I A L | |
|---|--------------------------|
| B1F | B1 |
| 1. Lever / Steel ASTM A36 Zinc Plated | |
| 2. Lever Nut, Screw / Steel ASTM A36 Zinc Plated | |
| 3. Packing Nut / Brass ASTM B124-C37710 | B124-C37700 |
| 4. Packing / Teflon PTFE | |
| 5. Stem O-ring / Viton (B-1F only) | |
| 6. Thrust Washer / Teflon PTFE (B-1F only) | |
| 7. Stem / Brass ASTM B124-C37710 | B124-C37700 |
| 8. Seats / Teflon PTFE | |
| 9. Body / Brass ASTM B124-C37710 | B283-C37700 |
| 10. Ball / Brass ASTM B124-C37710 Chrome Plated | B30-C85700 Chrome plated |
| 11. Cap / Brass ASTM B124-C37710 | B283-C37700 |

| D I M E N S I O N S | | | | | | | | | |
|---------------------|------|------|------|-------|-------|------|-------|------|-------|
| size (in.) | 1/2 | 3/4 | 1 | 1 1/4 | 1 1/2 | 2 | 2 1/2 | 3 | 4 |
| A | 55 | 61 | 74 | 84 | 90 | 104 | 117.7 | 141 | 163 |
| mm/in | 2.16 | 2.40 | 2.91 | 3.30 | 3.54 | 4.09 | 4.64 | 5.55 | 6.41 |
| B | 91 | 91 | 126 | 126 | 141 | 141 | 142 | 201 | 281 |
| mm/in | 3.58 | 3.58 | 4.96 | 4.96 | 5.55 | 5.55 | 5.63 | 7.87 | 11.06 |
| C | 49 | 52.5 | 59.6 | 65.6 | 73.2 | 82.5 | 90.5 | 117 | 132 |
| mm/in | 1.92 | 2.06 | 2.34 | 2.58 | 2.88 | 3.24 | 3.54 | 4.65 | 5.20 |
| D | 12.7 | 18.5 | 24 | 31 | 37 | 49.5 | 50 | 65 | 80 |
| mm/in | 0.50 | 0.72 | 0.94 | 1.22 | 1.45 | 1.94 | 1.96 | 2.55 | 3.14 |
| CV | 15 | 30 | 60 | 110 | 130 | 360 | | | |
| Weight | 0.40 | 0.55 | 1.0 | 1.4 | 2.1 | 3.2 | 4.8 | 7.8 | 11.8 |
| lb/kg | 0.19 | 0.25 | 0.45 | 0.64 | 0.96 | 1.5 | 2.2 | 3.6 | 5.4 |

