

B Series Forged Brass Ball Valves

B-1F

- Forged 2 piece construction
- Full port (1/2" to 2")
- Reduced port (2 1/2, 3" & 4")
- ASME B1.20.1 NPT ends
- Blowout-proof stem, Chrome plated ball
- Adjustable packing gland
- Secondary o-ring stem seal
- Class 150 WSP
- 1/2" to 2": 600 WOG (**B-1F**)
- 2 1/2" to 4": 400 WOG (**B-1**)

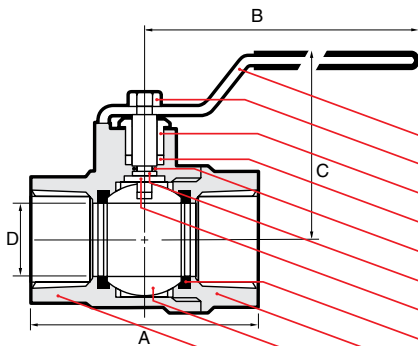

B-1F (1/2 to 2") is CSA approved for use with natural, manufactured, liquified petroleum & LP gas-air mixtures to ANSI Z21.15/CSA 9.1 (1/2 PSIG) -4° to 125°F

N A M E / M A T E R I A L

1. Lever / Steel ASTM A36 Zinc Plated
2. Lever Nut, Screw / Steel ASTM A36 Zinc Plated
3. Packing Nut / Brass ASTM B124-C37710
4. Packing / Teflon PTFE
5. Stem O-ring / NBR (**B-1F only**)
6. Thrust Washer / Teflon PTFE (**B-1F only**)
7. Stem / Brass ASTM B124-C37710
8. Seats / Teflon PTFE
9. Body / Brass ASTM B124-C37710
10. Ball / Brass ASTM B124-C37710 Chrome Plated
11. Cap / Brass ASTM B124-C37710

D I M E N S I O N S

size (in.)	1/2	3/4	1	1 1/4	1 1/2	2	2 1/2	3	4
A	52.4	58.4	72	82.2	88.6	105	117.7	141	163
mm/in	2.06	2.29	2.83	3.23	3.48	4.13	4.64	5.55	6.41
B	85	85	120	120	135	135	142	201	281
mm/in	3.34	3.34	4.72	4.72	5.31	5.31	5.63	7.87	11.06
C	44.9	49.4	58.5	64	73.3	80.8	90.5	117	132
mm/in	1.76	1.94	2.30	2.51	2.88	3.18	3.54	4.65	5.20
D	12.7	18.5	24	31	37	49.5	50	65	80
mm/in	0.50	0.72	0.94	1.22	1.45	1.94	1.96	2.55	3.14
CV	15	30	60	110	130	360			
Weight	0.40	0.55	1.0	1.4	2.1	3.2	4.8	7.8	11.8
lb/kg	0.19	0.25	0.45	0.64	0.96	1.5	2.2	3.6	5.4

