

B Series Forged Brass PEX Ball Valves

B-1PEX



- Forged 2 piece construction
- Reduced port
- ASTM F1807-08 PEX ends
- Blowout-proof stem
- Chrome plated ball
- O ring stem seals
- 400 WOG

NSF-61-9 certified
Drain available on model
B-1D PEX



5.8

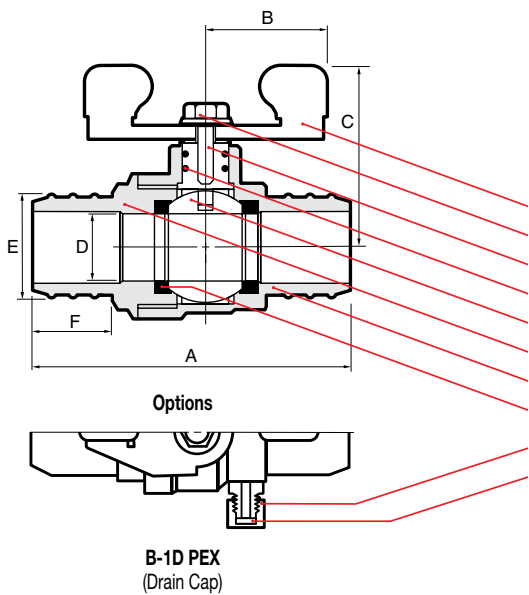

P A R T / M A T E R I A L

1. Handle / Steel ASTM A36
2. Handle Screw / Steel ASTM A36
3. Stem / Brass ASTM B124-C37700
4. O Ring / NBR
5. Ball / Brass ASTM B124-C37700 Chrome Plated
6. Cap / Brass ASTM B283-C37700
7. Body / Brass ASTM B283-C37700
8. Seat / Teflon PTFE
9. Drain Cap / Brass ASTM B124-C37700
10. Drain Cap Washer / NBR

D I M E N S I O N S

size (in.)	A mm/in	B mm/in	C mm/in	D mm/in	E mm/in	F mm/in	CV	Weight lb/kg
1/2	60.0	26.0	40.0	10.0	12.0	16.0	7	0.55
	2.36	1.02	1.57	0.39	0.47	0.63		0.250
3/4	64.0	26.0	41.8	12.7	16.9	16.0	13	0.79
	2.52	1.02	1.65	0.50	0.67	0.63		0.360
1	80.0	31.0	47.0	18.0	21.7	21.0	27	1.28
	3.15	1.22	1.85	0.71	0.85	0.83		0.580

***NOTE:**

- 1) The safe working pressure-temperature rating for this valve in a PEX piping system is dependent not only on the valve rating but also the limitations of the PEX pipe used. Refer to the CSA-B137 standard Table A1 below for these limits.

**Table A1: Pressure Rating for PEX SDR9
Water Distribution Systems**

Rated Temperature °C / °F	Pressure Rating for Water KPA / (PSI)
23 / 73	1105 / (160)
82 / 180	690 / (100)
93 / 200	550 / (80)

- 2) It is not recommended to use the drain feature valve B-1D PEX with any hostile fluid, gas or high temperature application.
- 3) Always depressurize system before removing the B-1D PEX drain cap.

