

B Series Forged Brass Ball Valves

B-3



LISTED
55AO
Trim & Drain



Forged 2 piece construction, Full port
ANSI B1.20.1 NPT ends
Blowout-proof stem, Chrome plated ball
Adjustable packing gland
Class 150 WSP, 600 WOG
NSF-61-8 certified
For use with natural, manufactured,
liquified petroleum & LP gas-air
mixtures to:
ANSI Z21.15/CSA 9.1 (1/2 PSIG)
ASME B16.44/CGA-CR91-002 (2 & 5 PSIG)
ASME B16.33/CGA-3.16 (125 PSIG)
-40° to 120°F

B3SS-LL (SS Trim) is available for 1/4" to 2"
NSF listing is not applicable to the B-3SS-LL

P A R T / M A T E R I A L

| B-3 | B-3SS-LL |
|---|------------------------|
| 1. Lever / Steel ASTM A36 | (AISI 430SS) |
| 2. Lever Screw / Steel ASTM A36 | (AISI 430SS) |
| 3. Packing Nut / Brass ASTM B124-C37700 | |
| 4. Packing / Teflon PTFE | |
| 5. Stem / Brass ASTM B124-C37700 | (ASTM A276 Type 316SS) |
| 6. Cap / Brass ASTM B283-C37700 | |
| 7. Seats / Teflon PTFE | |
| 8. Body / Brass ASTM B283-C37700 | |
| 9. Ball / Brass ASTM B124-C37700 Chrome Plated | (ASTM A276 Type 316SS) |
| 10. Wing and Latch lock handles / Steel A36 Zinc Plated | |

D I M E N S I O N S

| size (in.) | 1/4 | 3/8 | 1/2 | 3/4 | 1 | 1 1/4 | 1 1/2 | 2 | 2 1/2 | 3 | 4 |
|------------|------|------|------|------|-------|-------|-------|-------|-------|-------|-------|
| A | 44 | 44 | 54 | 62.2 | 72.4 | 83.2 | 96.4 | 110.3 | 150 | 173.2 | 192 |
| mm/in | 1.73 | 1.73 | 2.12 | 2.44 | 2.84 | 3.27 | 3.79 | 4.34 | 5.90 | 6.81 | 7.55 |
| B | 81 | 81 | 91.5 | 91.5 | 126.5 | 126.5 | 141.5 | 141.5 | 281 | 281 | 281 |
| mm/in | 3.18 | 3.18 | 3.60 | 3.60 | 4.98 | 4.98 | 5.57 | 5.57 | 11.06 | 11.06 | 11.06 |
| C | 39 | 39 | 53.4 | 57 | 65.3 | 70 | 83 | 90.5 | 118 | 130 | 143 |
| mm/in | 1.55 | 1.54 | 2.12 | 2.26 | 2.57 | 2.76 | 3.28 | 3.58 | 4.65 | 5.20 | 5.62 |
| D | 10 | 10 | 15 | 20 | 25 | 32 | 40 | 50 | 65 | 80 | 100 |
| mm/in | 0.39 | 0.39 | 0.59 | 0.78 | 0.98 | 1.25 | 1.57 | 1.96 | 2.55 | 3.14 | 3.93 |
| CV | 8 | 8 | 15 | 30 | 60 | 110 | 130 | 360 | 450 | 620 | 1200 |
| Weight | 0.25 | 0.25 | 0.50 | 0.75 | 1.2 | 1.8 | 2.7 | 3.9 | 8.4 | 11 | 16.5 |
| lb/kg | 0.12 | 0.12 | 0.23 | 0.34 | 0.55 | 0.82 | 1.23 | 1.8 | 3.8 | 5.0 | 9.5 |

P R E S S U R E T E M P E R A T U R E R A T I N G

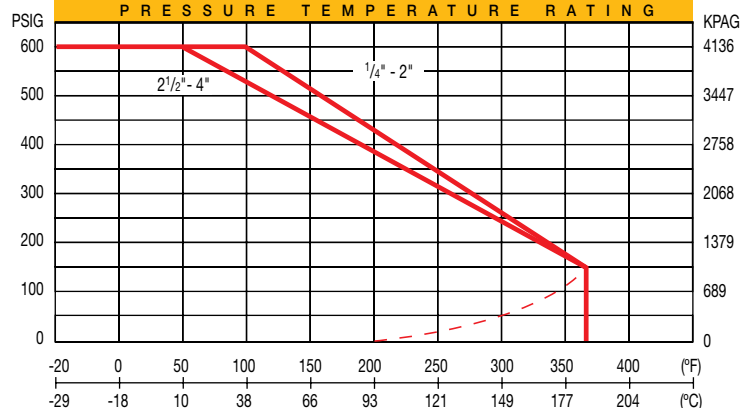

----- Max limit for saturated steam applications: 150 PSIG 366°F

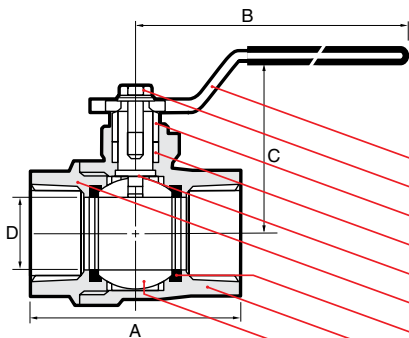

Options

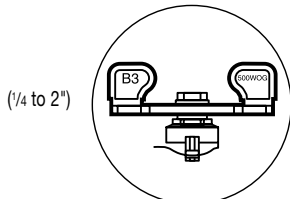

B3W
(wing handle)

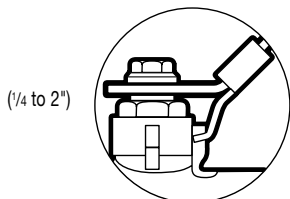

B3LL
(Latch lock handle)

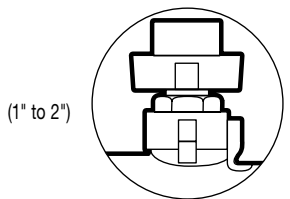

B3SH
(Square head operator)

*NOTES:

- 1) 2 1/2" and 3" sizes are certified for 1/2 to 5 PSIG gas services only
- 2) Gas certifications listed are not applicable to 4" size.
- 3) NSF & UL listings are not applicable to 2 1/2" - 4"