

# B Series Forged Brass Ball Valves with Drain

## B-3D

- Forged 2 piece construction
- Full port
- ANSI B1.20.1 NPT ends
- Blowout-proof stem
- Chrome plated ball
- Adjustable packing gland
- 600 WOG

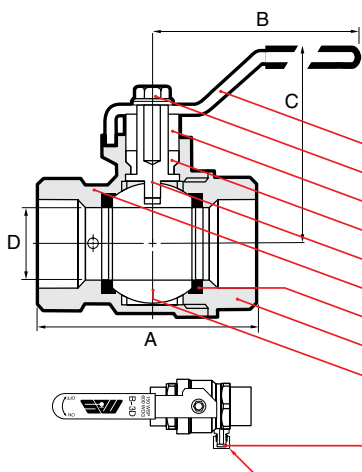

NAME / MATERIAL	
1.	Lever / Steel ASTM A36
2.	Lever Screw / Steel ASTM A36
3.	Packing Nut / Brass ASTM B124-C37700
4.	Packing / Teflon PTFE
5.	Stem / Brass ASTM B124-C37700
6.	Cap / Brass B-283-C37700
7.	Seat / Teflon PTFE
8.	Body / Brass B-283-C37700
9.	Ball / Brass B124/B283-C37700 Chrome plated
10.	Drain Cap Washer / NBR
11.	Drain Cap / Brass B124-C37700

DIMENSIONS			
size (in.)	1/2	3/4	1
A	61.5	70.6	81.0
mm/in	2.42	2.77	3.18
B	91.5	91.5	126.5
mm/in	3.60	3.60	4.98
C	54.4	57.8	66.3
mm/in	2.14	2.28	2.61
D	15.0	20.0	25.0
mm/in	0.59	0.78	0.98
CV	15	30	60
Weight	0.56	0.78	1.25
lb/kg	0.26	0.36	0.57

**NOTE:**

- 1) It is not recommended to use this drain feature valve in any hostile fluid, gas or high temperature application.

