

# B Series Forged Brass Ball Valves

## B-3



Forged 2 piece construction, Full port  
ANSI B1.20.1 NPT ends  
Blowout-proof stem, Chrome plated ball  
Adjustable packing gland  
Class 150 WSP, 600 WOG

### SS Trim available on model B-3SS-LL (1/4 to 2")

For use with natural, manufactured,  
liquefied petroleum & LP gas-air  
mixtures to:

ANSI Z21.15/CSA 9.1 (1/2 PSIG)  
ASME B16.44/CGA-CR91-002 (2 & 5 PSIG)  
ASME B1633/CGA-3.16 (125 PSIG)  
-40° to 120°F



5.3

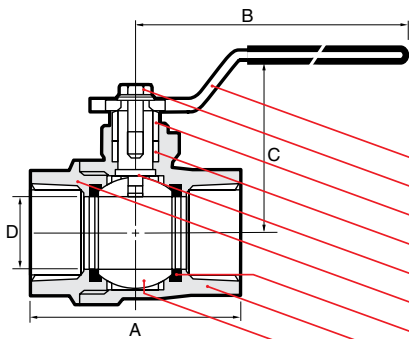

#### Options

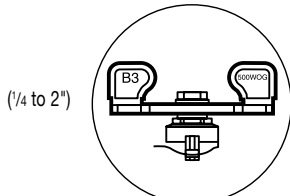

**B3W**  
(wing handle)

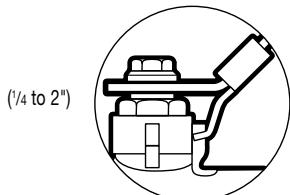

**B3LL**  
(Latch lock handle)

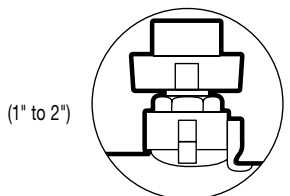

**B3SH**  
(Square head operator)

#### NOTES:

- 1) 2 1/2" and 3" sizes are certified for 1/2 and 5 PSIG gas services only
- 2) Gas certifications listed are not applicable to 4" size.

#### N A M E / M A T E R I A L

1. Lever / Steel ASTM A36	(AISI 430SS on model B-3SS-LL)
2. Lever Screw / Steel ASTM A36	(AISI 430SS on model B-3SS-LL)
3. Packing Nut / Brass ASTM B124-C37700	
4. Packing / Teflon PTFE	
5. Stem / Brass ASTM B124-C37700	(ASTM A276-316SS on model B-3SS-LL)
6. Cap / Brass ASTM B283-C37700	
7. Seats / Teflon PTFE	
8. Body / Brass ASTM B283-C37700	
9. Ball / Brass ASTM B124-C37700 Chrome Plated	(ASTM A276-316SS on model B-3SS-LL)
10. Wing and Latch lock handles / Steel A36 Zinc Plated	

#### D I M E N S I O N S

size (in.)	1/4	3/8	1/2	3/4	1	1 1/4	1 1/2	2	2 1/2	3	4
A	44	44	54	62.2	72.4	83.2	96.4	110.5	150	173.2	192
mm/in	1.73	1.73	2.12	2.44	2.84	3.27	3.79	4.34	5.90	6.81	7.55
B	81	81	91.5	91.5	126.5	126.5	141.5	141.5	281	281	281
mm/in	3.18	3.18	3.60	3.60	4.98	4.98	5.57	5.57	11.06	11.06	11.06
C	39.4	39	54	57.5	65.3	70	83.3	91	118	132	143
mm/in	1.55	1.54	2.12	2.26	2.57	2.76	3.28	3.58	4.65	5.20	5.62
D	10	10	15	20	25	32	40	50	65	80	100
mm/in	0.39	0.39	0.59	0.78	0.98	1.25	1.57	1.96	2.55	3.14	3.93
CV	8	8	15	30	60	110	130	360	450	620	1200
Weight	0.25	0.25	0.50	0.75	1.2	1.8	2.7	3.9	8.4	11	16.5
lb/kg	0.12	0.12	0.23	0.34	0.55	0.82	1.23	1.8	3.8	5.0	9.5

#### S E A T R A T I N G

