

B Series Forged Brass, 3-Port Diverter Ball Valves

B3-L

- 2 piece forged construction
- Reduced L-Port
- 2 seat design
- ANSI B1.20.1 NPT ends
- Blowout-Proof Stem
- Chrome Plated Ball
- O-ring stem seals
- Panel Mounting Holes
- Class 150 WSP, 400 WOG

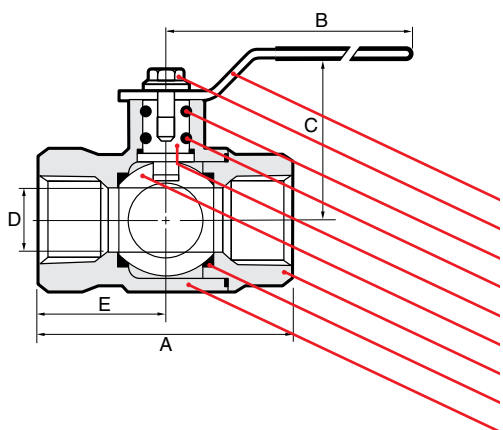

2 positions

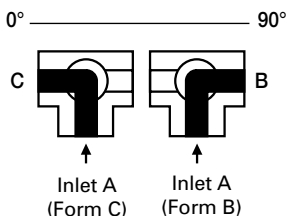

NAME / MATERIAL	
1.	Lever / Steel ASTM A36
2.	Lever Screw / Steel ASTM A36
3.	Stem O Ring / NBR
4.	Stem O Ring / Viton
5.	Stem / Brass ASTM B124-C37700
6.	Ball / Brass ASTM B124-C37700 Chrome Plated
7.	Cap / Brass ASTM B283-C37700
8.	Seat / Teflon PTFE
9.	Body / Brass ASTM B283-C37700

		DIMENSIONS									
size		10	15	20	25	32	40	50	65	80	
mm/in		3/8	1/2	3/4	1	1 1/4	1 1/2	2	2 1/2	3	
A	mm/in	49.0	56.0	68.0	80.0	91.0	102.0	120.0	142.0	169.0	
B	mm/in	1.93	2.20	2.68	3.15	3.58	4.02	4.72	5.59	6.65	
B	mm/in	81.0	81.0	91.5	91.5	126.5	126.5	141.5	141.5	281.3	
C	mm/in	3.19	3.19	3.60	3.60	4.98	4.98	5.57	5.57	11.07	
C	mm/in	34.5	34.5	47.5	50.5	54.0	59.5	73.4	81.5	103.3	
D	mm/in	1.36	1.36	1.87	1.99	2.13	2.34	2.89	3.21	4.07	
D	mm/in	10.0	10.0	15.2	20.2	25.0	32.0	40.0	50.0	65.0	
E	mm/in	0.39	0.39	0.59	0.80	0.98	1.26	1.57	1.97	2.56	
E	mm/in	28.5	28.5	34.0	40.0	45.5	51.0	60.0	71.0	84.5	
CV		0.96	0.96	1.34	1.57	1.79	2.01	2.36	2.80	3.33	
CV		1.2	3	5.5	12	18	30	39	65	115	
Weight		0.08	0.09	0.17	0.25	0.41	0.60	1.01	1.70	2.66	
lb/kg		0.167	0.205	0.384	0.551	0.896	1.315	2.215	3.750	5.851	

NOTES:

- The flow path pressure (A to B, or A to C) must exceed any closed port back pressure for proper seat sealing.

