

# B Series Cast Bronze 250 Steam Rated Ball Valves

## BZ-3SS-250

Cast 2 piece construction

Full Port

ANSI B1.20.1 NPT ends

Blowout-Proof Stem

**316SS Ball & Stem**

Adjustable Packing Gland

Locking Handle

**Steam Rated Seats and Seals**

1/2 to 2" **250 WSP** 600 WOG

2 1/2 to 3" **200 WSP** 400 WOG

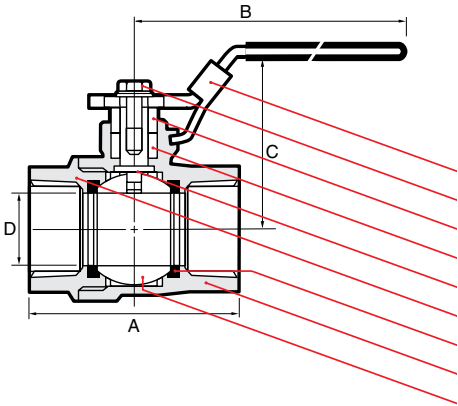

N A M E / M A T E R I A L	
1.	Lever / SS AISI type 430
2.	Lever Screw / SS AISI type 430
3.	Packing Nut / Brass ASTM B124-C37700
4.	Stem Packing / Teflon PTFE - Graphite
5.	Stem / SS ASTM A276 type 316
6.	Cap / Bronze ASTM B62 / B30-C83600
7.	Seat / Teflon PTFE - Graphite
8.	Body / Bronze ASTM B62 / B30-C83600
9.	Ball / SS ASTM A276 type 316

D I M E N S I O N S								
size	15	20	25	32	40	50	65	80
mm/in	1/2	3/4	1	1 1/4	1 1/2	2	2 1/2	3
A	57.0	67.0	77.0	91.0	103.0	122.0	153.0	179.2
mm/in	2.25	2.64	3.04	3.58	4.06	4.81	6.03	7.06
B	91.5	91.5	126.5	126.5	141.5	141.5	281.0	281.0
mm/in	3.60	3.60	4.98	4.98	5.57	5.57	11.07	11.07
C	54.0	57.5	65	71.0	83.0	91.0	119.0	131.0
mm/in	2.13	2.26	2.57	2.80	3.27	3.58	4.69	5.16
D	15.0	20.0	25.0	32.0	40.0	50.0	65.0	80.0
mm/in	0.59	0.79	0.98	1.26	1.57	1.97	2.56	3.15

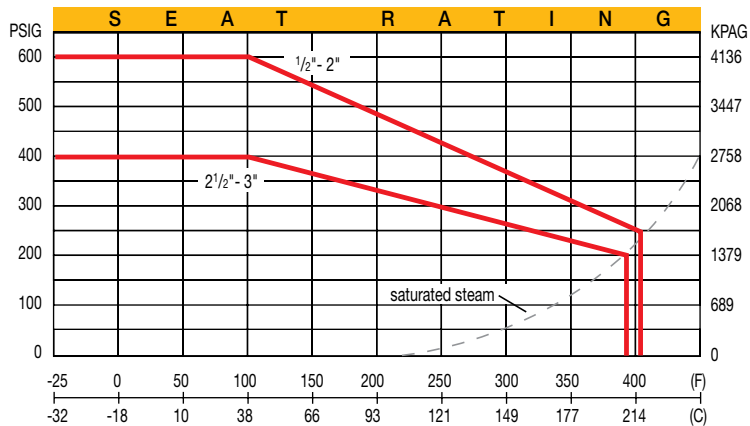

Max limit for saturated steam applications: 250 PSIG