

# B Series Cast Bronze Ball Valves

## BZ-3

Cast 2 piece construction  
Full Port  
ANSI B1.20.1 NPT ends  
Blowout-Proof Stem  
Chrome plated ball  
Adjustable Packing Gland  
Class 150 WSP  
1/2" to 2": 600 WOG  
2 1/2" to 3": 400 WOG

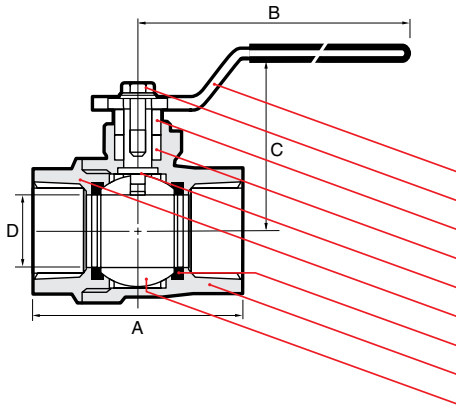

### N A M E / M A T E R I A L

1. Lever / Steel ASTM A36
2. Lever Screw / Steel ASTM A36
3. Packing Nut / Brass ASTM B124-C37700
4. Stem Packing / Teflon PTFE
5. Stem / Brass ASTM B124-C37700
6. Cap / Bronze ASTM B-62 / B30-C83600
7. Seat / Teflon PTFE
8. Body / Bronze ASTM B-62 / B30-C83600
9. Ball / Brass ASTM B124 / B283-C37700 / B30-C85700 Chrome plated

### D I M E N S I O N S

size	15	20	25	32	40	50	65	80
mm/in	1/2	3/4	1	1 1/4	1 1/2	2	2 1/2	3
A	57.0	67.0	77.0	91.0	103.0	122.0	153.0	179.2
mm/in	2.25	2.64	3.04	3.59	4.06	4.81	6.03	7.06
B	91.5	91.5	126.5	126.5	141.5	141.5	281.3	281
mm/in	3.60	3.60	4.98	4.98	5.57	5.57	11.07	11.07
C	54.0	57.5	65.3	71.0	83.0	91.0	119.3	131
mm/in	2.13	2.26	2.57	2.80	3.27	3.58	4.69	5.15
D	15.0	20.0	25.0	32.0	40.0	50.0	65.0	80.0
mm/in	0.59	0.79	0.98	1.26	1.57	1.97	2.55	3.14
Weight	0.60	0.80	1.0	2.10	3.7	5.85		
lb/kg	0.28	0.37	0.46	0.96	1.68	2.66		

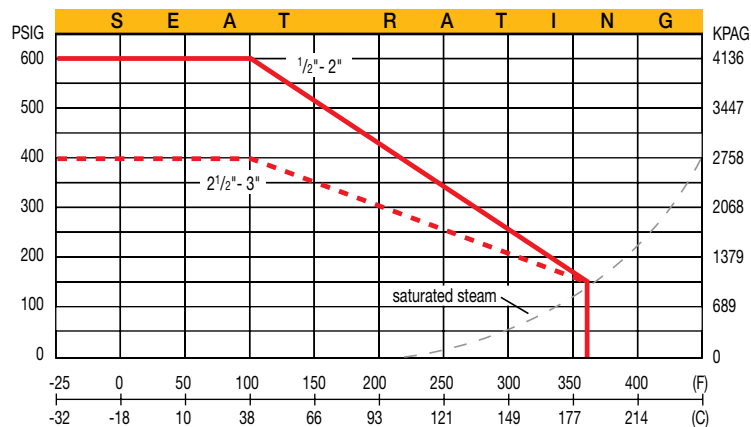

Max limit for saturated steam applications: 150 PSIG 366°F