

BZ Series Cast Bronze Ball Valves

BZ-4

- Cast 2 piece construction
- Full port
- ANSI B16.22 solder ends (CXC)
- Blowout-proof stem
- Chrome plated ball
- Adjustable packing gland
- Class 150, 600 WOG (1/2 to 1 1/2")
- Class 150, 400 WOG (2")
- Class 125, 200 WOG (2 1/2" to 3")

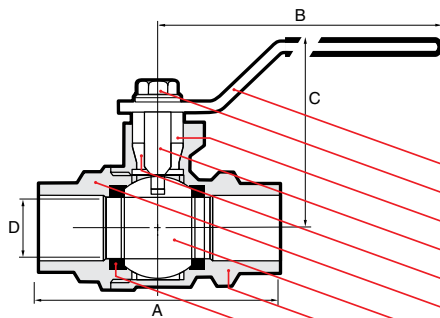

PART / MATERIAL

1. Lever / Steel ASTM A36
2. Lever Screw / Steel ASTM A36
3. Packing Nut / Brass ASTM B124-C37700
4. Stem / Brass ASTM B124-C37700
5. Stem Packing / Teflon PTFE
6. Cap / Bronze ASTM B62 / B30-C83600
7. Ball / Brass ASTM B124 / B283-C37700 or B30-C85700 chrome plated
8. Body / Bronze ASTM B62 / B30-C83600
9. Seats / Teflon PTFE

DIMENSIONS

size	15	20	25	32	40	50	65	80
mm/in	1/2	3/4	1	1 1/4	1 1/2	2	2 1/2	3
A	63.0	80.0	92.0	104.0	121.0	146.0	217	237
mm/in	2.48	3.15	3.63	4.10	4.77	5.75	8.54	9.33
B	91.5	91.5	126.5	126.5	141.5	141.5	281	281
mm/in	3.60	3.60	4.98	4.98	5.57	5.57	11.07	11.07
C	54.0	57.5	65.3	70.8	83.3	91.0	119.3	131.0
mm/in	2.13	2.26	2.57	2.79	3.28	3.58	4.69	5.15
D	15.0	20.0	25.0	32.0	40.0	50.0	65	78
mm/in	0.59	0.79	0.98	1.26	1.57	1.97	2.55	3.07

NOTES:

- 1) The safe working pressure-temperature rating for a solder joint piping system is dependent not only on valve seat rating but also on the limitations of the solder used for joints. Refer to ANSI B16.18 - Table A1 for the Maximum recommended pressure-temperature ratings for solder joints.
- 2) Exercise caution during installation by applying heat away from the valve body. Excessive direct flame may damage body seats and seals.

