

# BZ Series Cast Bronze, SS Trim, Locking Lever Ball Valves

## BZ-4SS

Cast 2 piece construction  
Full Port  
ANSI B16.18 solder ends (CXC)  
Blowout-Proof Stem  
**316SS Ball & Stem**  
Adjustable Packing Gland  
Locking Handle  
Class 150, 600 WOG (1/2 to 1 1/2)  
Class 150, 400 WOG (2")  
Class 125, 200 WOG (2 1/2 to 3")

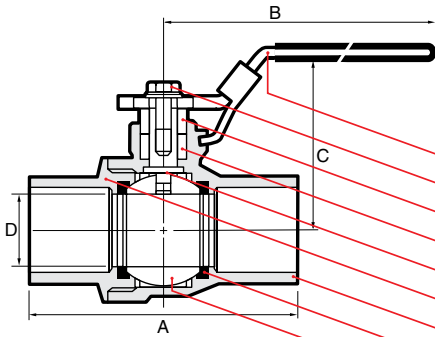

### PART / MATERIAL

1. Lever / SS AISI type 430
2. Lever Screw / SS AISI type 430
3. Packing Nut / Brass ASTM B124-C37700
4. Stem Packing / Teflon PTFE
5. Stem / SS ASTM A276 type 316
6. Cap / Bronze ASTM B62 / B30-C83600
7. Body / Bronze ASTM B62 / B30-C83600
8. Seat / Teflon PTFE
9. Ball / SS ASTM A276 type 316

	D I M E N S I O N S							
size	15	20	25	32	40	50	65	80
mm/in	1/2	3/4	1	1 1/4	1 1/2	2	2 1/2	3
A	63	80	92	104	121	146	217	237
mm/in	2.48	3.15	3.62	4.09	4.76	5.75	8.54	9.33
B	96	96	132	132	143	143	285	285
mm/in	3.77	3.77	5.19	5.19	5.62	5.62	11.22	11.22
C	52	56	69	75	89	97	124	135
mm/in	2.04	2.20	2.71	2.95	3.50	3.81	4.88	5.31
D	15.0	20.0	25.0	32.0	40.0	50.0	65	78
mm/in	0.59	0.79	0.98	1.26	1.57	1.97	2.56	3.07

### NOTES:

- 1) The safe working pressure-temperature rating for a solder joint piping system is dependent not only on valve seat rating but also on the limitations of the solder used for the joints. Refer to ANSI B16.18 Table A1 for the Maximum recommended pressure-temperature ratings for solder joints.
- 2) Exercise caution during installation by applying heat away from the valve body. Excessive direct flame may damage body seats and seals.

