

# C Series Carbon Steel Ball Valves

## CSS-F-3N-SW



Full port  
Socket Weld ends to ANSI B16.11  
Three Piece body  
Blowout-proof stem  
Adjustable packing nut  
Locking lever handle  
ISO 5211 mounting pad  
Complies to NACE MR-01-75  
Floating ball  
2000 PSI, W.O.G. 1/4" to 1"  
1500 PSI, W.O.G. 1 1/4" to 3"

**CSS-F-3N-BW (butt-weld)**  
available on request

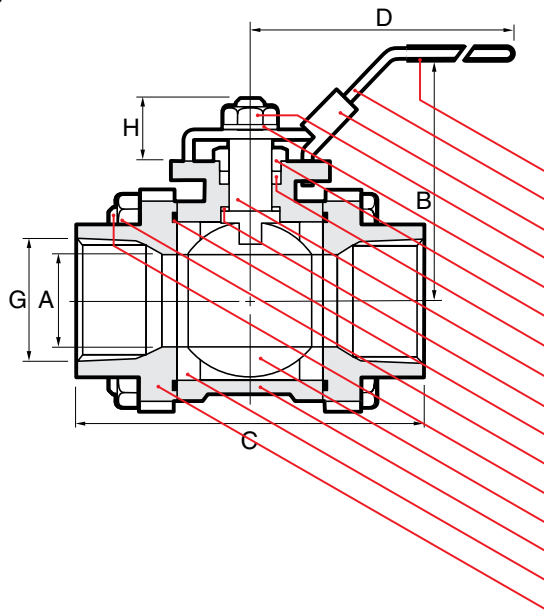
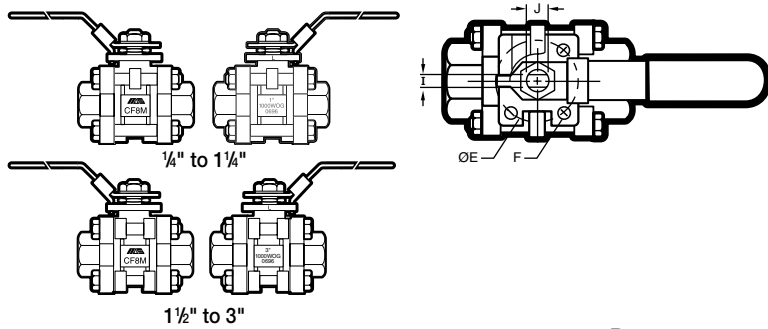

### NAME / MATERIAL

1. Handle Grip/ Vinyl
2. Handle / Stainless Steel 304 - A276
3. Locking Device / Stainless Steel 304 - A276
4. Handle Nut / Stainless Steel 304 - A 276
5. Stem Washer / Stainless Steel 304 - A276
6. Gland Nut / Carbon Steel A108
7. Packing / PTFE
8. Stem / Stainless Steel 316 - A276
9. Thrust Washer / Reinforced Teflon 15% GFT
10. Gasket / PTFE
11. Hex Nut / Carbon Steel A194 Grade 2HM
12. Bolt / Carbon Steel A193 Grade B7M
13. Ball / Stainless Steel 316 - A351
14. Body / Cast Steel A216 - WCB
15. Seat / Reinforced Teflon 15% GFT
16. Cap / Cast Steel A216 - WCB

### D I M E N S I O N S

size	8	10	15	20	25	32	40	50	65	80
mm/in	1/4	3/8	1/2	3/4	1	1 1/4	1 1/2	2	2 1/2	3
A	9.50	9.50	15.00	20.00	25.00	32.00	38.00	50.50	65.00	78.00
mm/in	0.374	0.374	0.591	0.787	0.984	1.260	1.496	1.988	2.559	3.071
B	67.00	67.00	68.50	75.00	79.00	88.50	94.50	107.00	129.50	139.50
mm/in	2.638	2.638	2.697	2.953	3.110	3.484	3.720	4.213	5.098	5.492
C	60.00	60.00	70.00	76.00	92.00	105.00	120.00	138.00	170.50	191.00
mm/in	2.362	2.362	2.756	2.922	3.622	4.134	4.724	5.433	6.713	7.520
D	120.00	120.00	120.00	139.00	139.00	193.00	193.00	193.00	244.00	244.00
mm/in	4.724	4.724	4.724	5.472	5.472	7.598	7.598	7.598	9.606	9.606
E	36.00	36.00	36.00	42.00	42.00	50.00	70.00	70.00	102.00	102.00
mm/in	1.417	1.417	1.417	1.653	1.653	1.968	2.756	2.756	4.016	4.016
F	M6	M6	M6	M6	M6	M8	M8	M8	M8	M8
ISO Flg	F03	F03	F03	F04	F04	F05	F07	F07	F10	F10
G	14.20	17.60	21.70	27.10	33.80	42.60	48.70	61.00	73.80	90.00
mm/in	0.559	0.693	0.854	1.067	1.330	1.677	1.917	2.402	2.906	3.543
H	11.50	12.50	14.50	18.00	18.00	23.50	22.50	25.00	32.50	31.00
mm/in	0.453	0.492	0.571	0.709	0.709	0.925	0.886	0.984	1.280	1.220
I	5.50	5.50	5.50	6.50	6.50	8.00	8.00	10.00	12.00	12.00
mm/in	0.217	0.217	0.217	0.256	0.256	0.315	0.315	0.394	0.472	0.472
J	7.70	7.70	7.70	9.30	9.30	12.50	12.50	15.60	18.80	18.80
mm/in	0.303	0.303	0.303	0.367	0.367	0.492	0.492	0.614	0.740	0.740
Weights	0.415	0.400	0.600	0.880	1.150	1.870	2.670	4.620	8.250	13.000
kg/lb	0.913	0.880	1.320	1.936	2.530	4.114	5.874	10.164	18.150	28.600
CV	10	10	26	50	68	120	170	360	510	900

