

G Series Investment Cast Stainless Steel Ball Valves

G1

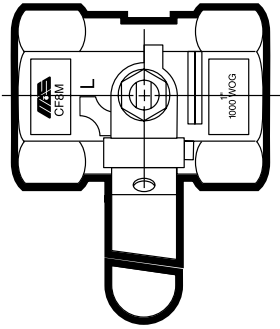

- Reduced port
- NPT ends to ANSI B1.20.1
- One piece body
- Blowout-proof stem
- Locking lever handle
- (Ring lock with 1/4" to 3/8",
Latch lock with 1/2" to 2")
- 1000 PSI, WOG 1/4" to 2"

4.1

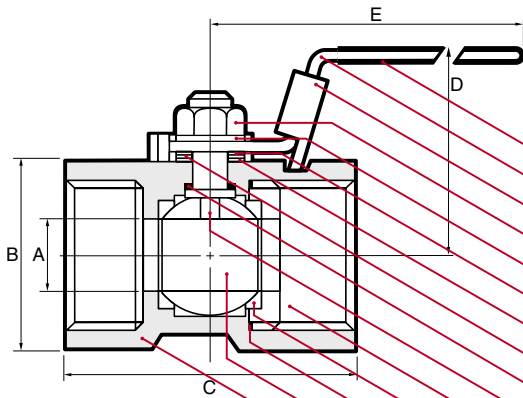

NAME / MATERIAL

1. Handle Grip / Vinyl
2. Handle / Stainless Steel 304-A276
3. Locking Device / Stainless Steel 304-A276
4. Handle Nut / Stainless Steel 304-A276
5. Stem Washer / Stainless Steel 304-A276
6. Belleville Washer / Stainless Steel 301
7. Packing / PTFE
8. Spring Washer / Stainless Steel 304-A276
9. Thrust Washer / Reinforced Teflon 15% GFT
10. Stem / Stainless Steel 316-A276
11. Seat Retainer / Stainless Steel 316-A276
12. Seat / Reinforced Teflon 15% GFT
13. Gasket / PTFE
14. Ball / Stainless Steel 316-A276 (A351-CF8M 1/2" to 2")
15. Body / Stainless Steel 316-CF8M

- Markings to MSS-SP25
- Available with Oval handle
- Material test results & inspection certificates available upon request
- CRN numbers available upon request

D I M E N S I O N S

size	8	10	15	20	25	32	40	50
mm/in	1/4	3/8	1/2	3/4	1	1 1/4	1 1/2	2
A	4.60	6.80	9.20	12.50	16.00	20.00	24.50	32.00
mm/in	0.181	0.268	0.362	0.492	0.630	0.787	0.965	1.260
B	17.00	21.50	26.00	32.00	38.00	49.00	52.50	66.00
mm/in	0.669	0.846	1.024	1.260	1.496	1.929	2.067	2.598
C	40.50	48.00	57.00	70.54	70.54	77.50	82.50	99.30
mm/in	1.594	1.890	2.244	2.323	2.777	3.051	3.248	3.909
D	34.00	35.50	43.00	48.50	60.00	61.50	70.50	83.00
mm/in	1.336	1.398	1.693	1.909	2.362	2.421	2.776	3.268
E	77.00	85.00	98.00	107.00	107.00	107.00	135.00	143.00
mm/in	3.031	3.346	3.858	3.858	4.212	4.212	5.315	5.630
CV	1.5	3.5	5.7	10.0	16.0	25.0	40.0	62.0
weights	0.072	0.112	0.208	0.271	0.428	0.705	0.826	1.380
kg/lb	0.158	0.246	0.458	0.596	0.942	1.551	1.817	3.036

P R E S S U R E T E M P E R A T U R E R A T I N G

