

G Series Investment Cast Stainless Steel, Deadman Spring Handle Ball Valves

G2-DM

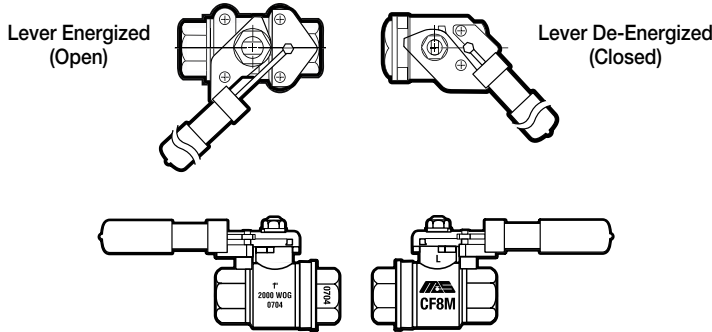

- Two piece body
- Full port
- NPT threads to ANSI B1.20.1
- Blowout-proof stem
- Adjustable packing nut
- Deadman handle
- Actuator mounting pad
- Floating ball
- 2000 P.S.I. W.O.G. 1/4" to 2"
- 1500 P.S.I. W.O.G. 2 1/2" & 3"



2.5

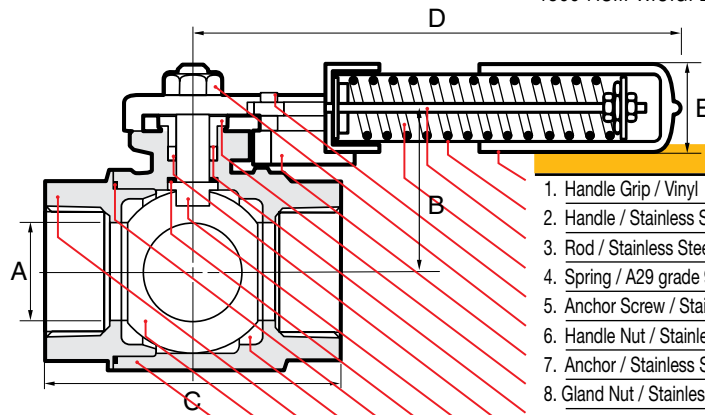

NAME / MATERIAL

1. Handle Grip / Vinyl
2. Handle / Stainless Steel A276 Type 304
3. Rod / Stainless Steel A276 Type 304
4. Spring / A29 grade 9260
5. Anchor Screw / Stainless Steel A276 Type 304
6. Handle Nut / Stainless Steel A276 Type 304
7. Anchor / Stainless Steel A351 grade CF8M (316)
8. Gland Nut / Stainless Steel A276 Type 304
- 9a. Packing Washer / PEEK
- 9b. Packing / RPTFE
10. Stem / Stainless Steel A276 Type 316
11. Thrust Washer / RPTFE
12. Gasket / PTFE
13. Seat / RPTFE
14. Cap / Stainless Steel A351 CF8M (316)
15. Ball / Stainless Steel A351 CF8M (316)
16. Body / Stainless Steel A351 CF8M (316)

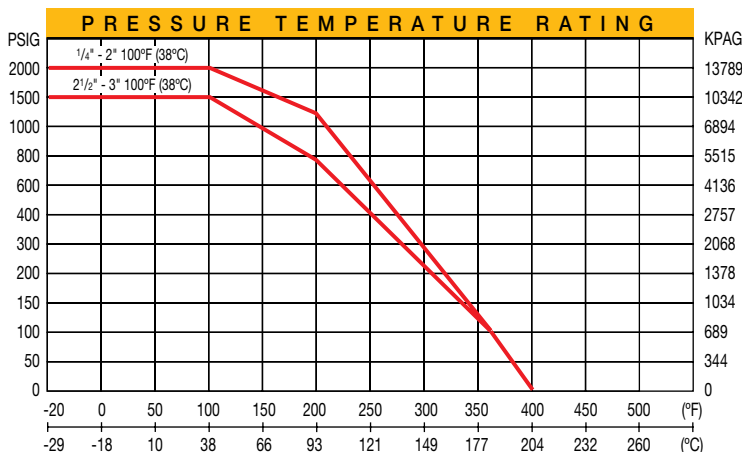

		D I M E N S I O N S									
size		8	10	15	20	25	32	40	50	65	80
A	mm/in	9.60 / 3/8	9.60 / 3/8	12.70 / 1/2	20.00 / 3/4	25.00 / 1	32.00 / 1 1/4	38.00 / 1 1/2	50.80 / 2	65.00 / 2 1/2	78.00 / 3
B	mm/in	0.374	0.374	0.500	0.787	0.984	1.260	1.496	2.000	2.559	3.071
B	mm/in	26.5	26.5	29.0	36.2	39.3	51.3	57.2	67.6	82.7	92.7
C	mm/in	1.043	1.043	1.142	1.425	1.547	2.021	2.253	2.662	3.255	3.649
C	mm/in	55.40	55.40	62.00	73.10	86.00	94.00	116.00	134.00	164.00	180.00
D	mm/in	2.181	2.181	2.441	2.878	3.386	3.700	4.567	5.276	6.457	7.086
D	mm/in	180.50	180.50	180.50	232.0	232.0	290.0	290.0	313.0	313.0	313.0
E	mm/in	7.106	7.106	7.106	9.154	9.154	11.417	11.417	12.323	12.323	12.323
E	mm/in	22.0	22.0	22.0	22.0	22.0	22.0	22.0	32.0	32.0	32.0
E	mm/in	0.866	0.866	0.866	0.866	0.866	0.866	0.866	1.260	1.260	1.260
CV		7.0	7.0	15.0	45.0	65.0	125.0	175.0	380.0	500.0	900.0
weights		0.605	0.595	0.658	0.872	1.112	1.556	2.655	3.746	6.552	9.672
kg/lb		1.334	1.312	1.451	1.922	2.451	3.430	5.853	8.258	14.444	21.323