

G Series Investment Cast Stainless Steel Direct Mount Ball Valves

G2-ED

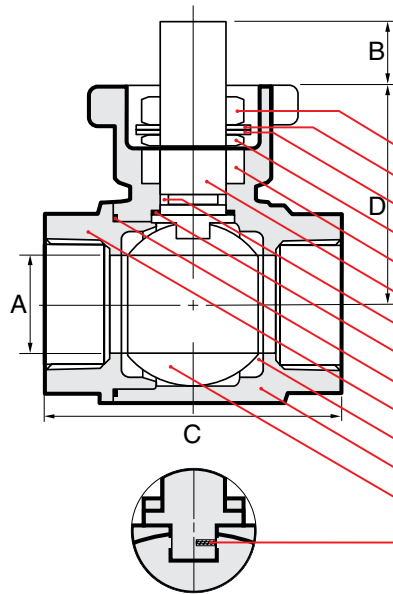
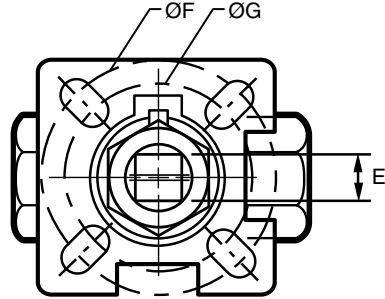

- Full port
- NPT threads to ANSI B1.20.1
- Two piece body
- Blowout-proof stem
- ISO 5211 Direct Mounting Pad
- Adjustable Live-loaded Packing
- Anti-static Device
- Floating Ball
- 1000 PSI, WOG 1/2" to 2"

**Compatible with Max-Air/
MAS Actuators**

NAME / MATERIAL

1. Packing Nut / Stainless Steel A276 Type 304
2. Lock Washer / Stainless Steel A276 Type 304
3. Belleville Washer / Stainless Steel A276 Type 304
4. Packing Gland / Stainless Steel A276 Type 304
5. Packing / PTFE
6. Stem / Stainless Steel A276 Type 316
7. Stem Seal / VITON O-ring
8. Thrust Washer / RPTFE (MG1241)
9. Gasket / PTFE
10. Cap / Stainless Steel A351- CF8M (316)
11. Seat / Reinforced Teflon 15% GFT
12. Body / Stainless Steel A351- CF8M (316)
13. Ball / SS A351- CF8M (316)
14. Spring & Pin Anti-static Device / Stainless Steel A276 Type 304

D I M E N S I O N S

size	15	20	25	32	40	50
mm/in	1/2	3/4	1	1 1/4	1 1/2	2
A	15.0	20.0	24.0	31.8	38.1	50.0
mm/in	0.590	0.787	0.945	1.252	1.500	1.968
B	10.0	10.0	11.0	11.0	17.0	17.0
mm/in	0.394	0.394	0.433	0.433	0.669	0.669
C	58.2	66.0	77.7	90.4	102.4	119.0
mm/in	2.291	2.598	3.059	3.559	4.031	4.685
D	36.3	39.5	50.5	56.0	70.6	79.0
mm/in	1.429	1.555	1.988	2.205	2.779	3.110
E	9.0	9.0	11.0	11.0	14.0	14.0
mm/in	0.354	0.354	0.433	0.433	0.551	0.551
F	42.0	42.0	70.0	50.0	70.0	70.0
mm/in	1.653	1.653	2.756	1.968	2.756	2.756
G	36.0	36.0	50.0	42.0	50.00	50.00
mm/in	1.417	1.417	1.968	1.653	1.968	1.968
CV	15.0	45.0	65.0	125.0	175.0	380.0
weights	0.208	0.398	0.703	1.040	1.690	2.700
kg/lb	0.458	0.876	1.547	2.288	3.718	5.940

P R E S S U R E T E M P E R A T U R E R A T I N G

