

# G Series Investment Cast Stainless Steel 1000 WOG Ball Valves

## G2E



Full port  
NPT ends to ANSI B1.20.1  
Two piece body  
Blowout-proof stem  
Adjustable packing nut  
Locking lever handle  
Floating ball  
1000 PSI, WOG 1/4" to 3"  
P-T 100 PSI @ 450°F

2.2

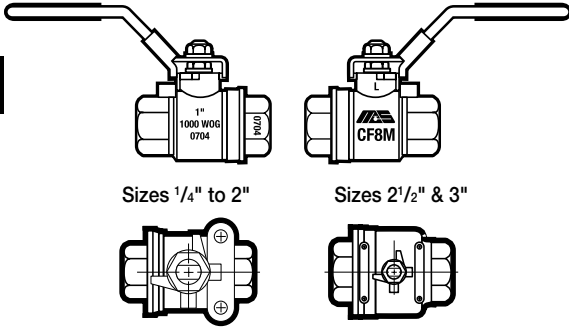

Sizes 1/4" to 2"

Sizes 2 1/2" & 3"

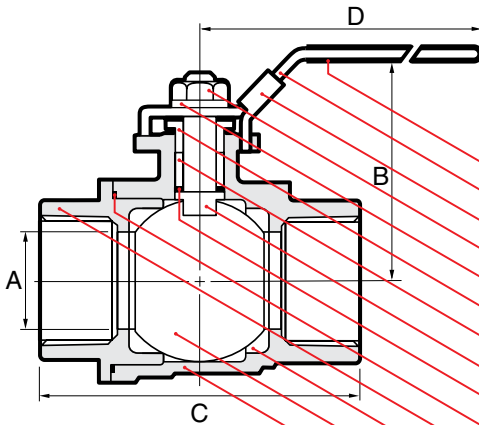

### NAME / MATERIAL

1. Handle Grip / Vinyl
2. Handle / Stainless Steel A276 Type 304
3. Locking Device / Stainless Steel A276 Type 304
4. Handle Nut / Stainless Steel A276 Type 304
5. Stem Washer / Stainless Steel A276 Type 304
6. Gland Nut / Stainless Steel A276 Type 304
7. Packing / Reinforced Teflon 15% GFT
8. Stem / Stainless Steel A276 Type 316
9. Thrust Washer / Reinforced Teflon 15% GFT
10. Gasket / Reinforced Teflon 15% GFT
11. Cap / Stainless Steel A351 - CF8M (316)
12. Seat / Reinforced Teflon 15% GFT
13. Ball / Stainless Steel A351 - CF8M (316)
14. Body / Stainless Steel A351 - CF8M (316)

D I M E N S I O N S										
size	8	10	15	20	25	32	40	50	65	80
mm/in	1/4	3/8	1/2	3/4	1	1 1/4	1 1/2	2	2 1/2	3
A	9.6	9.6	12.7	20.0	24.0	31.8	38.1	50.0	65.0	78.0
mm/in	0.378	0.378	0.500	0.787	0.945	1.252	1.50	1.968	2.559	3.071
B	54.0	54.0	54.6	64.8	67.8	79.4	84.4	100.7	135.0	145.00
mm/in	2.126	2.126	2.150	2.551	2.669	3.126	3.323	3.965	5.315	5.709
C	49.4	49.4	56.0	66.0	77.7	90.4	102.4	119.0	151.4	171.4
mm/in	1.945	1.945	2.205	2.598	3.059	3.559	4.031	4.685	5.961	6.748
D	98.0	98.0	98.0	122.0	122.0	152.0	152.0	178.0	247.0	247.0
mm/in	3.858	3.858	3.858	4.803	4.803	5.984	5.984	7.008	9.724	9.724
CV	7.0	7.0	15.0	45.0	65.0	125.0	175.0	380.0	500.0	900.0
weights	0.20	0.21	0.235	0.43	0.63	1.11	1.49	2.60	5.42	8.38
kg/lb	0.440	0.462	0.517	0.946	1.386	2.442	3.278	5.720	11.924	18.436

