



M. A. Stewart & Sons Ltd.
VALVES AND FITTINGS

G Series Investment Cast Stainless Steel 3 Port-Diverter Ball Valves

G4

- Three way L-port
- Reduced port
- NPT ends to ANSI B1.20.1
- Two piece body with floating ball
- Blowout-proof stem
- Adjustable packing gland
- Locking lever handle
- ISO 5211 mounting pad
- 1000 PSI, WOG 1/4" to 2"



2.11

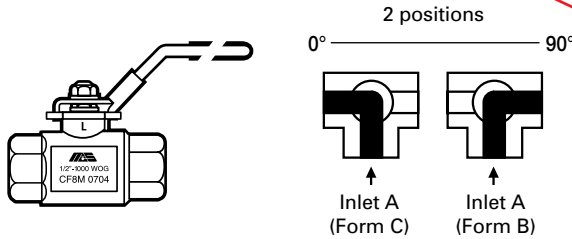
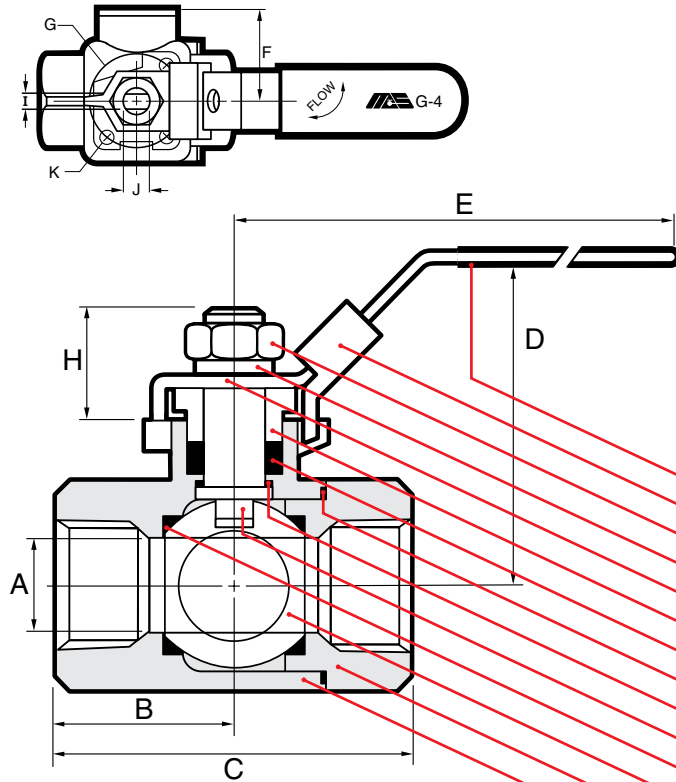

NAME / MATERIAL

1. Handle Grip / Vinyl
2. Locking Device / Stainless Steel 304 - A276
3. Handle Nut / Stainless Steel 304 - A276
4. Stem Washer / Stainless Steel 304 - A276
5. Handle / Stainless Steel 304 - A276
6. Gland Nut / Stainless Steel 304 - A276
7. Stem Packing / PTFE
8. Gasket / PTFE
9. Thrust Washer / Reinforced Teflon 15% GFT
10. Stem / Stainless Steel 316 - A276
11. Seat / Reinforced Teflon 15% GFT
12. Ball / Stainless Steel 316 - A351 - CF8M
13. Cap / Stainless Steel 316 - A351 - CF8M
14. Body / Stainless Steel 316 - A351 - CF8M

D I M E N S I O N S

size	8	10	15	20	25	32	40	50
mm/in	1/4	3/8	1/2	3/4	1	1 1/4	1 1/2	2
A	11.10	12.70	12.70	17.30	20.60	25.40	31.80	38.10
mm/in	0.44	0.50	0.50	0.68	0.81	1.00	1.25	1.50
B	29.35	29.35	29.35	38.10	40.75	51.00	55.50	68.50
mm/in	1.16	1.16	1.16	1.50	1.60	2.01	2.19	2.70
C	58.70	58.70	58.70	76.20	82.00	102.00	111.00	137.00
mm/in	2.31	2.31	2.31	3.00	3.23	4.02	4.37	5.39
D	50.80	50.80	50.80	58.50	62.35	74.10	78.85	94.20
mm/in	2.00	2.00	2.00	2.29	2.46	2.92	3.10	3.71
E	100.00	100.00	100.00	130.00	130.00	155.00	155.00	175.00
mm/in	3.94	3.94	3.94	5.12	5.12	6.10	6.10	6.89
F	30.00	30.00	30.00	38.10	42.67	51.00	61.00	71.37
mm/in	1.18	1.18	1.18	1.50	1.68	2.01	2.40	2.81
G	36.00	36.00	36.00	36.00	42.00	50.00	50.00	50.00
mm/in	1.42	1.42	1.42	1.42	1.65	1.97	1.97	1.97
H	15.30	15.30	15.30	17.00	18.40	23.00	23.00	25.40
mm/in	0.60	0.60	0.60	0.67	0.72	0.91	0.91	1.00
I	5.45	5.45	5.45	6.45	6.45	8.00	8.00	10.00
mm/in	0.22	0.22	0.22	0.25	0.25	0.32	0.32	0.39
J	7.70	7.70	7.70	9.30	9.30	12.50	12.50	15.50
mm/in	0.30	0.30	0.30	0.37	0.37	0.49	0.49	0.61
K	M6 x 1.0	M6 x 1.0	M6 x 1.0	M6 x 1.0	M6 x 1.0	M8 x 1.25	M8 x 1.25	M8 x 1.25
CV	4	5.4	5.4	12	15	21	34	47
weights	0.390	0.360	0.330	0.660	0.850	1.490	2.040	3.160
kg/lb	0.858	0.792	0.726	1.452	1.870	3.278	4.488	6.952

NOTES:

- 1) The flow path pressure (A to B, or A to C) must exceed any closed port back pressure for proper seat sealing.

