

RED-WHITE

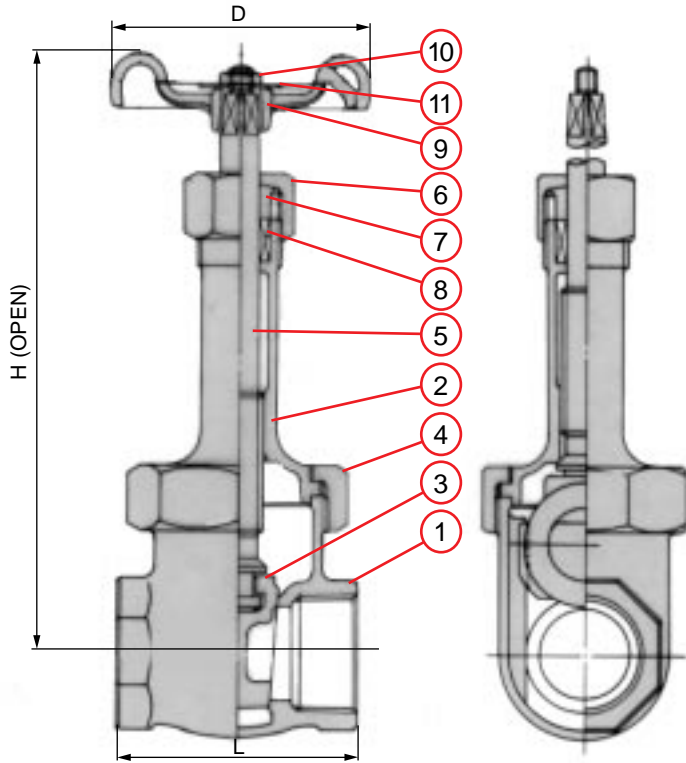

125 - POUND BRONZE GATE VALVES

Rising stem, union bonnet, solid wedge disc, screwed ends..



MSS Specification Valves



WORKING PRESSURES

Working pressure Non - shock		Test pressure	
Saturated steam	Cold water Oil, Gas	Shell (Water)	Seat (Air)
Psig 125	200	300	80
Bar 8.6	13.8	20.7	5.5

Note:

1. End threads conform to the American or British standard pipe threads.
2. These valves conform to the requirements of MSS SP-80.

*Design and materials are subject to change without notice.

M A T E R I A L S

No.	Name of parts	ASTM specification	
1	Body	Cast bronze	B62-C83600
2	Bonnet	Cast bronze	B62-C83600
3	Disc	Cast bronze	B62-C83600
4	Union nut	Cast bronze	B62-C83600
5	Stem	Cast bronze	B505-C83600
6	Packing nut	³ / ₈ - 2 ¹ / ₂	Forged brass B283-C37700
		3	Cast bronze B62-C83600
7	Gland	Forged brass	B124-C37700
8	Gland packing	Non-asbestos packings T#2996-NA	
9	Handwheel	³ / ₈ & ¹ / ₂	Zinc alloy die casting B86-Z33520
		³ / ₄ - 4	Aluminum alloy die casting B85-A03840
10	Wheel nut	Steel (Zinc plated)	A563 Gr. A
11	Name plate	Aluminum plate	B209-1100

D I M E N S I O N S

size (in.)	³ / ₈	¹ / ₂	³ / ₄	1	1 ¹ / ₄	1 ¹ / ₂	2	2 ¹ / ₂	3
L	47	54	58	67	73	77	84	106	115
mm/in	1.85	2.13	2.28	2.64	2.87	3.03	3.31	4.18	4.53
H	121	138	158	193	221	250	305	368	426
mm/in	4.76	5.43	6.22	7.60	8.70	9.84	11.97	14.49	16.77
D	48	55	63	70	80	90	100	125	125
mm/in	1.89	2.17	2.48	2.76	3.15	3.54	3.94	4.92	4.92
Weight	0.86	1.10	1.56	2.40	3.28	4.33	6.71	11.12	15.42
lb/kg	0.39	0.50	0.71	1.09	1.49	1.97	3.05	5.10	7.01

Toyo Valve Co., Ltd.