

RED-WHITE



150 - POUND BRONZE GATE VALVES

Rising stem, union bonnet, solid wedge disc, screwed ends.

MSS Specification Valves

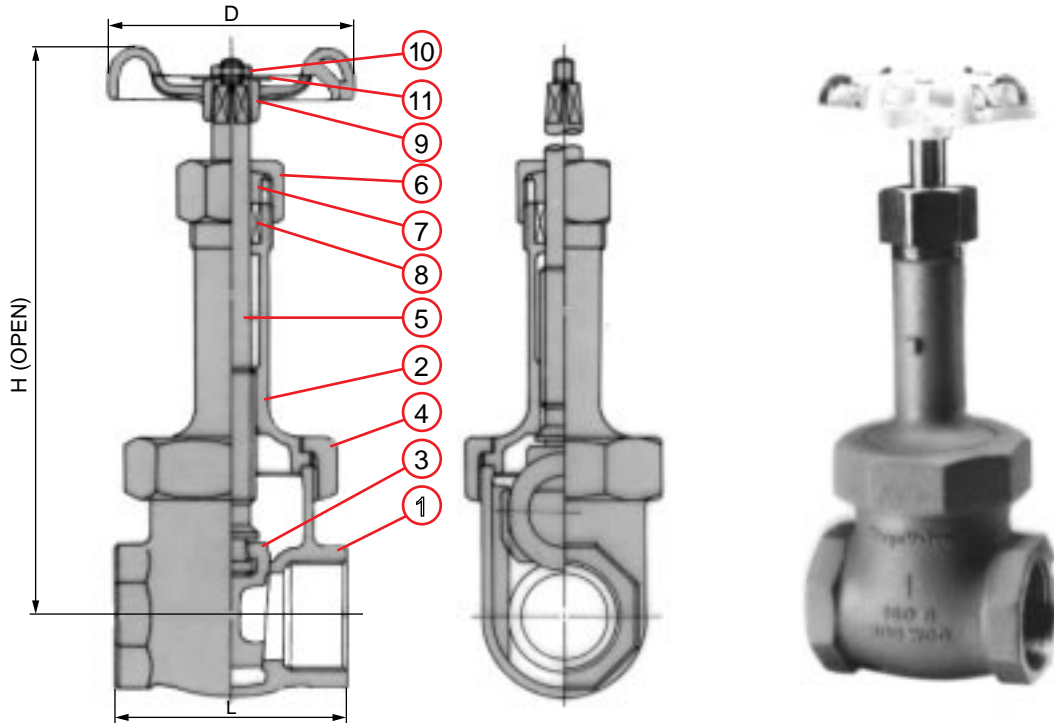

WORKING PRESSURES			
Working pressure Non - shock		Test pressure	
Saturated Steam	Cold water Oil, Gas	Shell (Water)	Seat (Air)
Psig 150	300	450	80
Bar 10.3	20.7	31.0	5.5

Note:

1. End threads conform to the American or the British standart pipe threads.
2. These valves conform to the requirements of MSS-SP 80.

*Design & materials are subject to change without notice.

M A T E R I A L S			
No.	Name of parts	ASTM specification	
1	Body	Cast bronze	B62-C83600
2	Bonnet	Cast bronze	B62-C83600
3	Disc	Cast bronze	B62-C83600
4	Union nut	Cast bronze	B62-C83600
5	Stem	Cast bronze	B505-C83600
6	Packing nut	³ / ₈ - 2 ¹ / ₂	Forged brass
		3	Cast bronze
7	Gland	Forged brass	B124-C37700
8	Gland packing	Non-asbestos packings	
9	Hand wheel	³ / ₈ & ¹ / ₂	Zinc alloy die casting
		³ / ₄ - 3	Aluminum alloy die casting
10	Wheel nut	Steel (Zinc plated)	A563
11	Name plate	Aluminum plate	B209-1100

D I M E N S I O N S									
size (in.)	³ / ₈	¹ / ₂	³ / ₄	1	1 ¹ / ₄	1 ¹ / ₂	2	2 ¹ / ₂	3
L	47	54	58	67	73	77	84	106	115
mm/in	1.85	2.13	2.28	2.64	2.87	3.03	3.31	4.18	4.53
H	121	133	158	193	221	250	304	368	426
mm/in	4.76	5.24	6.22	7.60	8.68	9.84	11.97	14.49	16.75
D	48	55	63	70	80	90	100	125	125
mm/in	1.89	2.17	2.48	2.76	3.15	3.54	3.94	4.92	4.92
Weight	0.86	1.10	1.56	2.40	3.31	4.30	6.59	11.31	15.74
lb/kg	0.39	0.50	0.72	1.09	1.50	1.95	2.99	5.13	7.14

Toyo Valve Co., Ltd.