

RED-WHITE



300 - POUND BRONZE GATE VALVES

Rising stem, union bonnet, solid vedge disc, stainless steel seat, screwed ends.

MSS Specification Valves

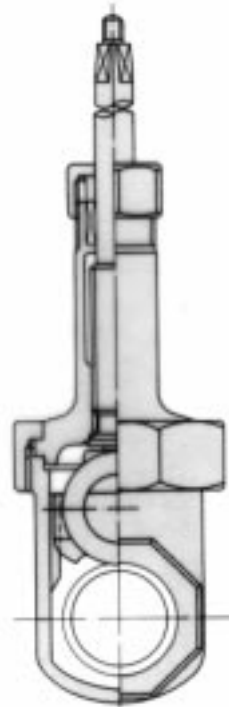
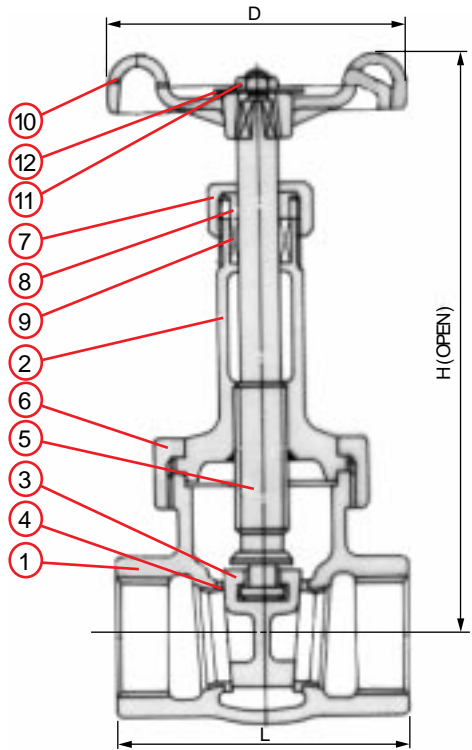

WORKING PRESSURES

Working pressure Non - shock		Test pressure	
Saturated Steam	Cold water Oil, Gas	Shell (Water)	Seat (Air)
Psig 300	1000	1500	80
Bar 20.7	69.0	103.4	5.5

M A T E R I A L S

No.	Name of parts	ASTM specification	
1	Body	Cast bronze	B61-C92200
2	Bonnet	Cast bronze	B61-C92200
3	Disc	Cast bronze	B61-C92200
4	Body seat ring	Stainless steel	A276-Type 403
5	Stem	Cast bronze	B505-C83600
6	Union nut	Cast bronze	B61-C92200
7	Packing nut	Forged brass	B283-C37700
8	Gland	Forged brass	B124-C37700
9	Gland packing	Non-asbestos packings	T#2996-NA
10	Handwheel	Aluminum alloy die casting	B85-A03840
11	Wheel nut	Steel (Zinc plated)	A563 Gr. A
11	Name plate	Aluminum plate	B209-1100

Note:

- End threads conform to the American or British standard pipe threads.
- These valves conform to the requirements of MSS SP-80.

*Design & materials are subject to change without notice.

D I M E N S I O N S

size (in.)	1/2	3/4	1	1 1/4	1 1/2	2
L	60	68	78	86	94	108
mm/in	2.36	2.68	3.07	3.39	3.70	4.25
H	138	162	190	225	254	310
mm/in	5.43	6.38	7.48	8.86	10.00	12.20
D	63	70	80	90	100	110
mm/in	2.48	2.76	3.15	3.54	3.94	4.33
Weight	1.06	1.48	2.25	3.42	4.81	7.50
lb/kg	0.48	0.67	1.02	1.55	2.18	3.40

Toyo Valve Co., Ltd.