

RED-WHITE

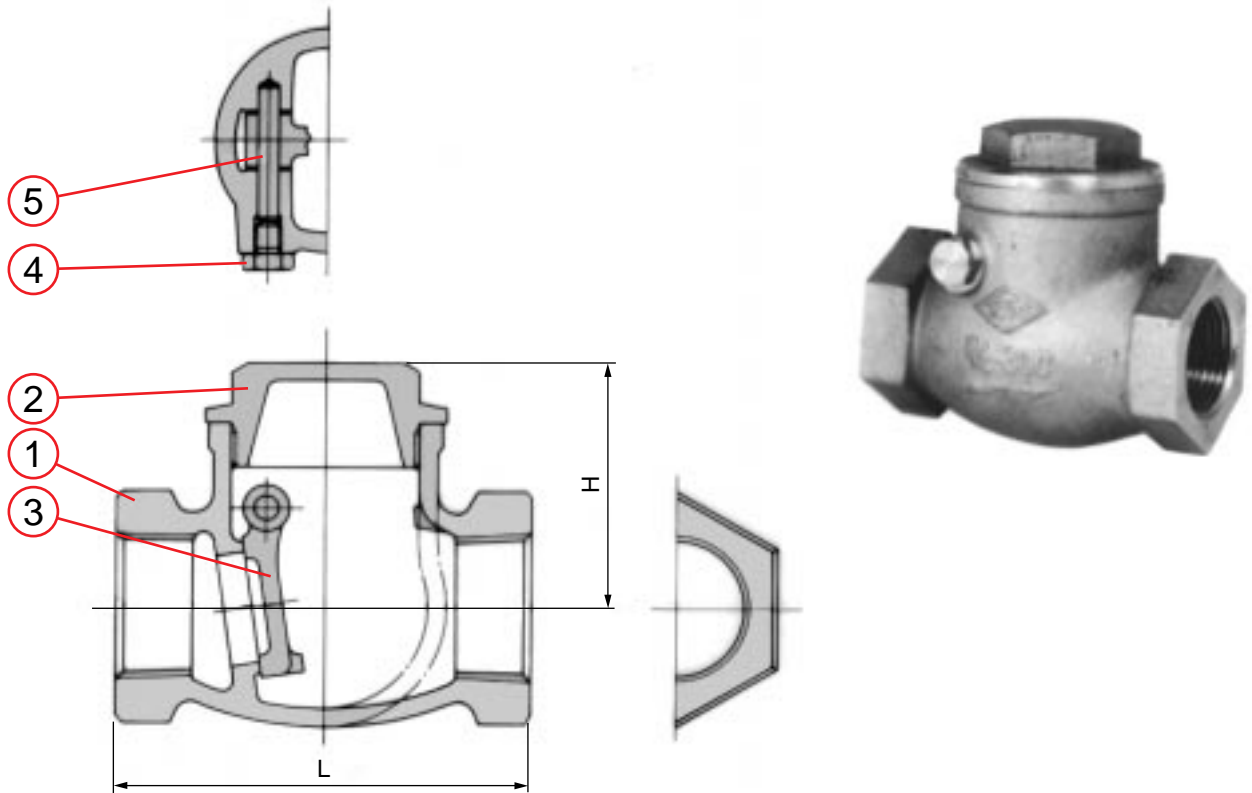

300 - POUND BRONZE CHECK VALVES

Swing type, screwed cap, bronze disc, screwed ends.



WORKING PRESSURES

Working pressure Non - shock		Test pressure	
Saturated Steam	Cold water Oil, Gas	Shell (Water)	Seat (Air)
Psig 300	600	900	50
Bar 20.7	41.4	62.1	3.5

M A T E R I A L S

No.	Name of parts	ASTM specifications	
1	Body	Cast bronze	B61-C92200
2	Cap	Cast bronze	B61-C92200
3	Disc	Cast bronze	B61-C92200
4	Plug	Brass rod	B16-C36000
5	Hanger pin	Copper alloy rod	B21-C47940

*Toyo's patented corrosion resistant material.

Note:

End threads conform to the American or British standard pipe threads.

D I M E N S I O N S

size (in.)	1/2	3/4	1	1 1/4	1 1/2	2
L	70	78	92	111	122	148
mm/in	2.76	3.07	3.62	4.37	4.80	5.83
H	43	50	57	72	72	86
mm/in	1.69	1.97	2.24	2.83	2.83	3.39
Weight	0.87	1.32	2.07	3.48	4.74	7.54
lb/kg	0.39	0.60	0.94	1.58	2.15	3.43

*Design and materials are subject to change without notice.

Toyo Valve Co., Ltd.