

RED-WHITE



125-POUND CAST IRON GLOBE VALVES

MSS Specification Valves



Outside screw and yoke, rising stem,
bolted bonnet, flanged ends.

Pressure-Temperature Ratings

Service Temperature		Sizes 2" to 12"	
°F	°C	Psig	Bar
-20 to 150	-29 to 66	200	13.7
200	93	190	13.1
225	107	180	12.4
250	121	175	12.0
275	135	170	11.7
300	149	165	11.3
325	163	155	10.6
353(5)	178	150	10.3
375	191	145	10.0
406(6)	208	140	9.6
425	218	130	8.9
450	232	125	8.6
Hydrostatic test pressure	Shell	350	24.1
	Seat	200	13.7

1. Pressure temperature ratings extracted from ASME B16.1 apply to cast iron flanged end valves designed for primary working pressures in Class 125.
2. Pressure ratings specified above are used for cast iron valves with metal-to-metal seating surfaces. Pressure-temperature ratings for cast iron valves with non-metallic seat materials must be limited to reflect the physical characteristics of these materials at each temperature and may be lower, but in no case higher than values shown in the above table.
3. The temperature shown to a corresponding pressure rating shall be the metal temperature of pressure containing parts. It shall be assumed that the metal temperature will be the temperature of the contained fluid.
Application of a pressure rating at a metal temperature other than that of the contained fluid is strictly limited to the responsibility of the user.
4. The pressure rating in service shall be restricted to the minimum temperature of -20° F (-29° C) as shown above.
5. 353° F (Max.) to reflect the temperature of saturated steam at 125 psig.
6. 406° F (Max.) to reflect the temperature of saturated steam at 250 psig.

Materials

No.	Name of Parts	ASTM Specifications	
1	Body	Cast iron	A126 Class B
2	Body seat ring	Cast bronze	B62-C83600
3	Disc seat ring	Cast bronze	B62-C83600
4	Disc	Cast iron	A126 Class B
5	Guide spindle	Brass	B16-C36000
6	Disc nut	Brass	B16-C36000
7	Washer	Brass	B16-C36000
8	Stem	Brass	B16-C36000
9	Bonnet bush	Brass	B16-C36000
10	Bonnet bolt	Steel*	A307 Grade B
11	Bonnet bolt nut	Steel*	A307 Grade B
12	Packings	Non-asbestos packings	
13	Gland	Brass	B16-C36000
14	Gland flange	Ductile iron	A536
15	Gland bolt	Steel*	A307 Grade B
16	Gland bolt nut	Steel*	A307 Grade B
17	Bonnet	Cast iron	A126 Class B
18	Stem nut	Brass	B16-C36000
19	Set screw	Steel*	A307 Grade B
20	Hand wheel	Cast iron	A126 Class B
21	Name plate	Aluminum	
22	Wheel nut	Steel*	A307 Grade B

*Zinc plated

FIG. NO. 400AE

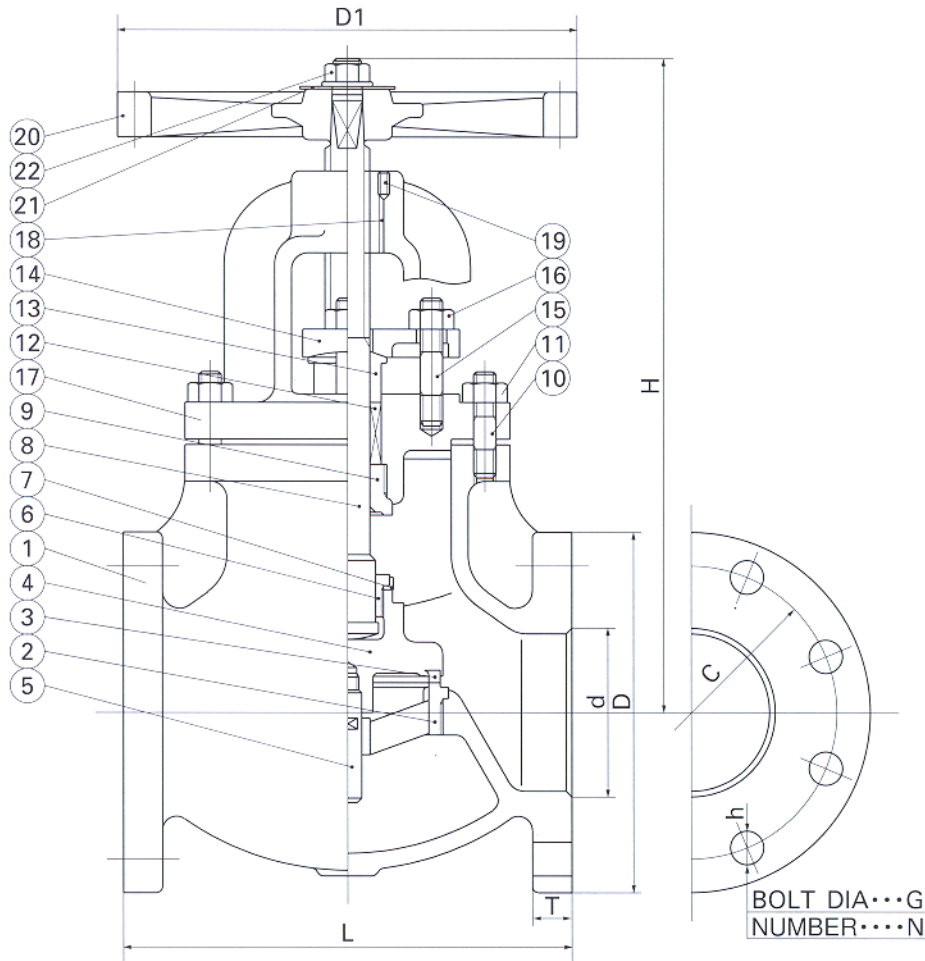

Marking on the body

6
125S
200WOG



One side

RED-WHITE



Other side

Note:

1. Face-to-face dimensions conform to ASME B 16. 10.
2. End flange dimensions and drillings conform to ASME B 16. 1. End flanges are fully flat faced and smoothly finished in accordance with MSS SP-6.
3. JIS10K and BS/DIN PN16 flanged ends are available upon request.
4. Drain boss and by-pass bosses are available upon request.
5. Valves conform to MSS SP-85.

Dimensions

Size (in)	Mark (mm)	L	H	D ₁	Flanges					
					D	C	T	N	h	G
2	in.	8	12.6	7.87	6.00	4.75	0.62	4	0.75	0.62
	mm	203	320	200	152	121	15.9		19.0	15.9
2½	in.	8.5	13.58	7.87	7.00	5.50	0.69	4	0.75	0.62
	mm	216	345	200	178	140	17.5		19.0	15.9
3	in.	9.5	15.24	10	7.50	6.00	0.75	4	0.75	0.62
	mm	241	387	254	191	152	19.0		19.0	15.9
4	in.	11.5	19.29	11.81	9.00	7.50	0.94	8	0.75	0.62
	mm	292	490	300	229	191	23.8		19.0	15.9
5	in.	13	22.68	13.78	10.00	8.50	0.94	8	0.88	0.75
	mm	330	576	350	254	216	23.8		22.2	19.0
6	in.	14	26.77	15.75	11.00	9.50	1.00	8	0.88	0.75
	mm	356	680	400	279	241	25.4		22.2	19.0
8	in.	19.5	31.81	17.72	13.50	11.75	1.12	8	0.88	0.75
	mm	495	808	450	343	299	28.6		22.2	19.0
10	in.	24.5	39.76	19.88	16.00	14.25	1.19	12	1.00	0.88
	mm	622	1010	505	406	362	30.2		25.4	22.2
12	in.	27.5	42.52	24.02	19.00	17.00	1.25	12	1.00	0.88
	mm	698	1080	610	483	432	31.8		25.4	22

Weight

lb.	kg.
51	23
66	30
84	38
132	60
174	79
234	106
417	189
666	302
908	412

*Design and materials are subject to change without notice.