

RED-WHITE

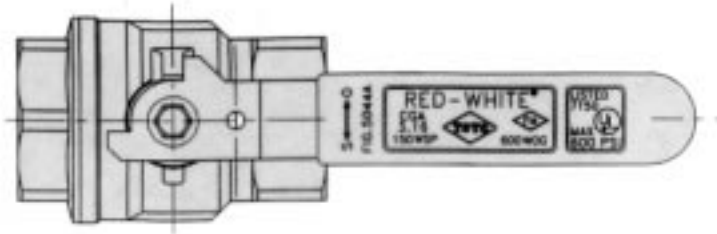

# 600 - POUND BRASS BALL VALVES

Full bore, 2-piece body, blowout-proof system, screwed ends.



MSS Specification Valves CGA / AGA / UL / FM Approved  
( Sizes 1/2" to 2" )

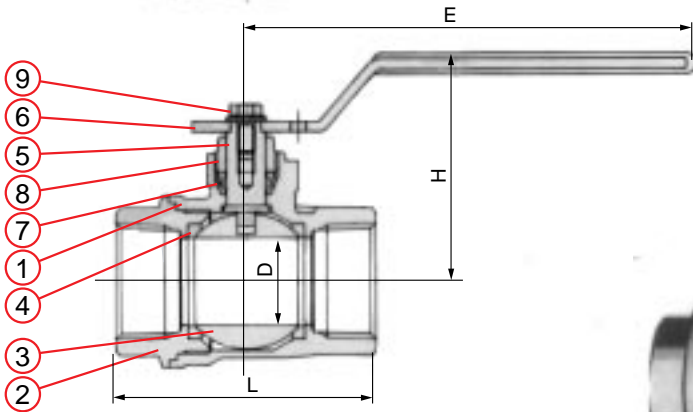

WORKING PRESSURES			
Working pressure Non - shock		Test pressure	
Steam	Cold water Oil, Gas	Shell (Water)	Seat (Air)
Psig 150	600	900	80
Bar 10.3	41.4	62.1	5.5

M A T E R I A L S			
No.	Name of parts	ASTM specification	
1	Body	Forged brass	B283-C37700
2	Cap	Forged brass	B283-C37700
3	Ball	1/4 - 1 1/4	Forged brass**
		1 1/2 - 3	Cast brass**
4	Seat	Teflon®	
5	Stem	Forged brass	B124-C37700
6	Lever handle	Steel*	A36
7	Gland packing	Teflon®	
8	Gland	Forged brass	B124-C37700
11	Handle bolt	Steel*	A36

® DuPont's tradename  
\*Zinc plated  
\*\*Hard chromium plated

**Note:**

1. End threads conform to the American standard pipe threads.
2. These valves conform to the requirements of MSS SP-110.
3. These valves (sizes 1/2" to 2") are approved by Canadian/American Gas Association, Underwriters Laboratories and Factory Mutual.
4. Memory stop is available on request. This ball valve with memory stop can be opened to the same preset position each time.

\*Design & materials are subject to change without notice.

D I M E N S I O N S										
size (in.)	1/4	3/8	1/2	3/4	1	1 1/4	1 1/2	2	2 1/2	3
L	44	44	54	65	74	86	99	113	153	173
mm/in	1.73	1.73	2.13	2.56	2.91	3.39	3.90	4.45	6.02	6.81
H	40	40	53.5	57	65	71	83	91	120	131
mm/in	1.57	1.57	2.11	2.24	2.56	2.80	3.27	3.58	4.72	5.16
E	82.5	82.5	92.5	92.5	128	128	143	143	284	284
mm/in	3.25	3.25	3.64	3.64	5.04	5.04	5.63	5.63	11.18	11.18
D	10	10	15	20	25	32	40	50	65	80
mm/in	0.39	0.39	0.59	0.79	0.98	1.26	1.57	1.97	2.56	3.15

**Toyo Valve Co., Ltd.**