

RED-WHITE

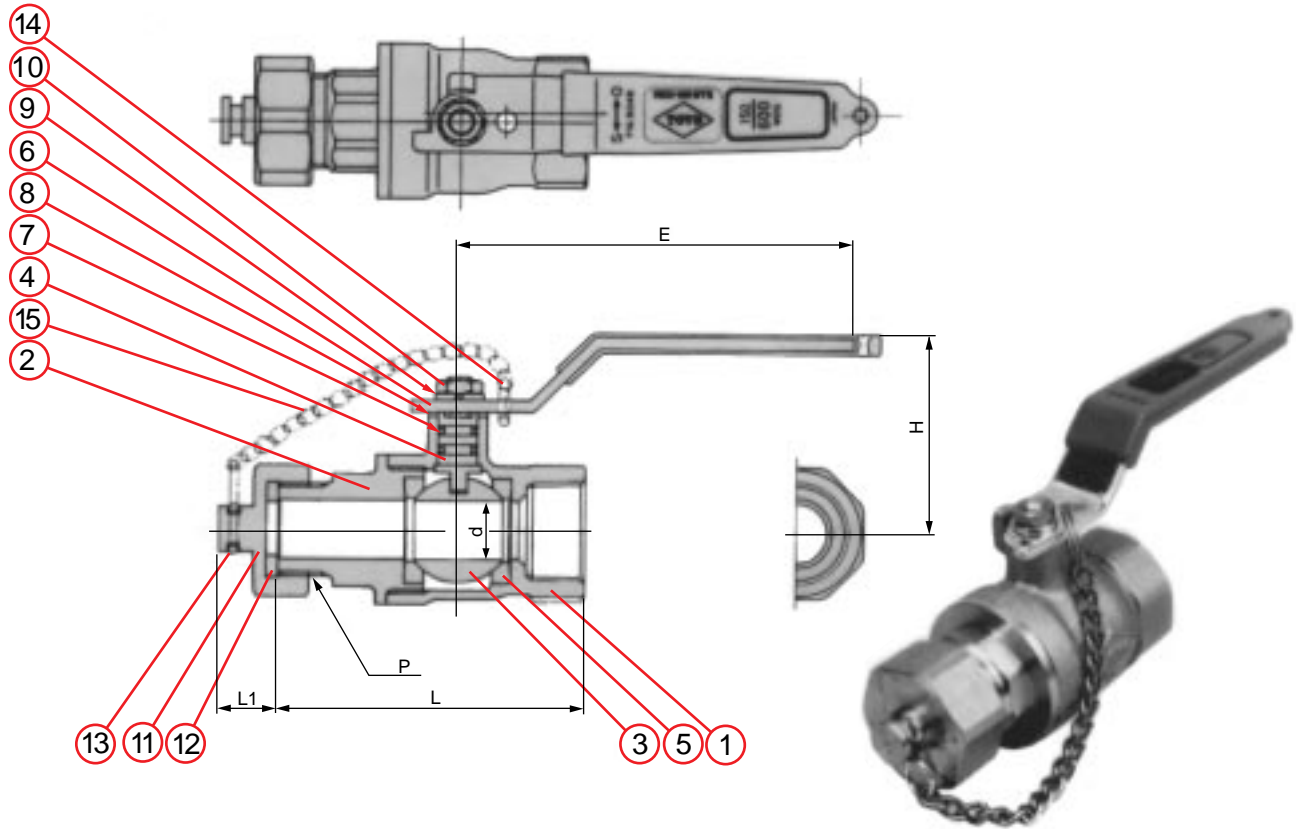

600 - POUND BRASS BALL VALVES

2- piece body, blowout - proof stem, with cap, screwed ends



D I M E N S I O N S					
size (in.)	3/4	1	1 1/4	1 1/2	2
L	78	94	98	109	126
mm/in	3.07	3.70	3.86	4.29	4.96
L _i	15	15	15	15	15
mm/in	0.59	0.59	0.59	0.59	0.59
H	52	57	59	65	74
mm/in	2.05	2.24	2.32	2.56	2.91
E	100	120	130	130	150
mm/in	3.94	4.72	5.12	5.12	5.94
d	17.5	22.5	25	32	40
mm/in	0.69	0.89	0.98	1.26	1.57
P	3/4	1	1 1/4	1 1/2	2
	11.5NHR	11.5NPSH	11.5NPSH	11.5NPSH	11.5NPSH
Weight	1.09	1.64	2.31	3.36	4.87
lb/kg	0.50	0.75	1.05	1.53	2.21

M A T E R I A L S		
No.	Name of parts	ASTM specification
1	Body	Forged brass B283-C37700
2	Body Cap	Forged brass B124-C37700
3	Ball	Forged brass (Hard chromium plated) B283-C37700
4	Stem	Forged brass B124-C37700
5	Seat	Teflon®
6	Lever handle	Steel* A36
7	*O* ring	Viton® + Buna-N
8	Thrust washer	Teflon®
9	Spring washer	Steel wire* A227
10	Nut	Steel* A563 Gr. A
11	Cap	Brass rod B16-C36000
12	Packing	Buna-N
13	Ring	Steel wire* A227
14	Ring	Steel wire* A227
11	Chain	Steel A36

® DuPont's tradename
*Zinc plated

Note:

- Hose coupling screw threads conform to ANSI B2.4.
- End threads conform to ANSI B2.1 taper pipe threads.

*Design & materials are subject to change without notice.

W O R K I N G P R E S S U R E S			
Working pressure Non - shock		Test pressure	
Steam	Cold water Oil, Gas	Shell (Water)	Seat (Air)
Psig 150	600	900	80
Bar 10.3	41.4	62.1	5.5

Toyo Valve Co., Ltd.