

MOYGRO

check valve



M.A. Stewart & Sons Ltd.
VALVES AND FITTINGS

Features

Compact Design - Short face-to-face length enabling installation in restricted spaces not possible with conventional check valves.

Spring Assisted Closure - Providing faster dynamic response to reduce water hammer, eliminating expensive replacement costs.

Drip-Tight Closure - Positive tight sealing with soft seat options.

Ease of Maintenance - Simple construction with readily available Service Kits.

Comprehensive Range - A full range of sizes 50 mm (2") through 900 mm (36") in Pressure Classes ASME 125,

150, 300 to International Standards ASME, BS, API594.

Versatility - Through optional features, including extended shaft with backflush lever, position indicator, counter weight, dampers, external springs and slam retarders.

Made in Australia - More than 30 years proven design and performance. Sold worldwide for applications in all major industries.

Approvals - Underwriters Laboratories of Canada (for specific models).

Quality Assurance - ISO 9001 - Crane Australia.

Dimensions - Materials & Parts List

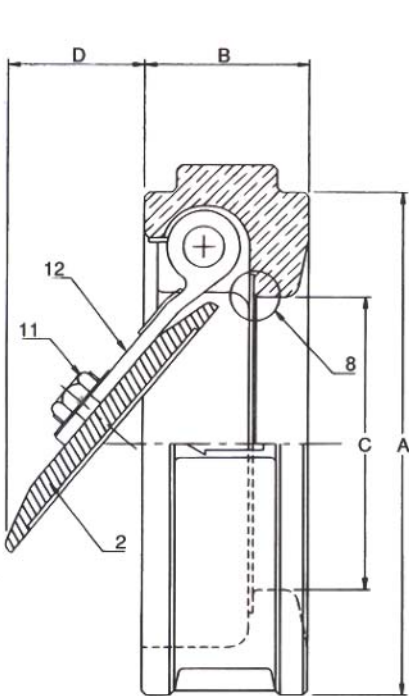

Size mm	A BSTD BSTE	A ASME125 ASME 150	A ASME 300	A BS4504 NP16	B Std	B API 594 #150	B API 594 #300	C	D Std	D API 594 #150	D API 594 #300
50	98.4	104.8	111.1	109	44.15	60	60	33.3	28.6	13	13
65	111.1	123.8	-	129	47.6	-	-	42.9	30.2	-	-
80	130.2	136.5	149.2	144	50.5	73	73	52.4	55.6	34	34
100	161.9	174.6	181.0	164	57.2	73	73	76.2	74.6	59	59
125	193.7	196.9	-	194	63.5	-	-	95.3	95.3	-	-
150	215.9	222.3	250.8	220	69.9	98	98	120.7	114.3	86	86
200	273.1	279.4	308.3	275	73.0	127	127	183.5	155.6	102	102
250	336.6	339.7	362.3	331	79.4	146	146	193.7	187.3	121	121
300	394.2	409.6	422.3	386	85.7	181	181	241.3	222.3	127	127
350	447.7	450.9	485.8	446	108.0	184	222	266.7	228.6	152	114
400	498.5	514.4	539.8	498	108.0	191	232	317.5	247.7	165	124
450	562.0	549.3	596.9	558	108.0	203	264	355.6	298.5	203	143
600	619.2	606.4	654.1	620	139.7	219	292	387.4	323.9	245	171
600	727.1	717.6	774.7	737	152.4	222	318	462.6	387.4	318	222
750	895.3	882.7	-	-	152.4	-	-	584.2	527.1	-	-
900	1060.0	1048.0	-	-	152.4	-	-	736.6	635.0	-	-

Size inch	A BSTD BSTE	A ASME125 ASME 150	A ASME 300	A BS4504 NP16	B Std	B API 594 #150	B API 594 #300	C	D Std	D API 594 #150	D API 594 #300
2	3.875	4.125	4.375	4.291	1.750	2.38	2.36	1.312	1.125	0.49	0.49
2.5	4.375	4.875	-	5.079	1.875	-	-	1.688	1.188	-	-
3	5.125	5.375	5.875	5.669	2.000	2.88	2.88	20.62	2.188	1.31	1.31
4	6.375	6.875	8.125	6.457	2.250	2.88	2.88	3.000	2.938	2.30	2.30
5	7.625	7.750	-	7.38	2.500	-	-	3.750	3.750	-	-
6	8.500	8.750	9.875	8.661	2.750	3.88	3.8	4.750	4.500	3.37	3.37
8	10.750	11.00	12.125	10.827	2.875	5.00	5.0	6.347	6.125	4.00	4.00
10	13.250	13.375	14.250	13.031	3.125	5.75	5.75	7.625	7.375	4.75	4.75
12	15.125	16.125	16.625	15.197	3.375	7.12	7.12	9.500	8.750	5.03	5.00
14	17.625	17.750	19.125	17.559	4.250	7.25	8.75	10.500	9.000	6.00	4.50
16	19.625	20.250	21.250	19.606	4.250	7.50	9.12	12.500	9.750	6.50	4.88
18	22.125	21.625	23.500	21.969	4.250	8.00	10.38	14.000	11.750	8.00	5.62
20	24.375	23.875	25.750	24.409	5.500	8.62	11.50	15.250	12.750	9.63	6.75
24	28.625	28.250	30.500	29.016	6.000	8.75	12.50	19.000	15.250	12.50	8.75
30	35.250	34.750	-	-	6.000	-	-	23.000	20.750	-	-
36	41.750	41.250	-	-	6.000	-	-	29.000	25.000	-	-

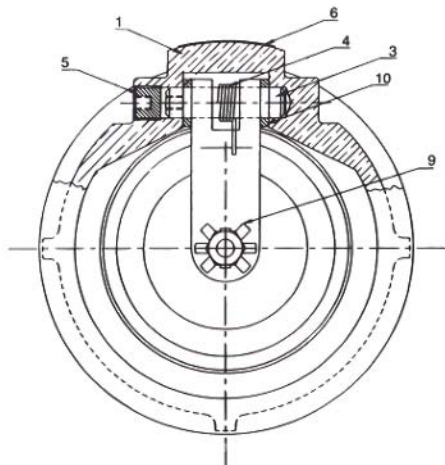

REF & SEAT OPTIONS



Item	Qty	Description	Material	Notes
1	1	Body	Cast Iron (Class 40) Cast Steel (WCB) Stainless Steel (CF8M)	
2	1	Clapper	316 SS	(4)
3	1	Hinge Pin	316 SS	(4)
4	1	Torsion Spring	316 SS / Inconel	(1), (3), (4)
5	1	Plug	Cad Plated Steel	
6	1	ID Tag	Aluminium	
8	1	Seat	Viton A Optional Nitrile Optional PTFE Stainless Body Only Steel Body Only	(3), (4)
9	1	Tab Washer	316 SS	(3), (4)
10	1	Thrust Washer	PTFE / 316 SS	(2), (3), (4)
11	1	Clapper Nut	316 SS	(4)
12	1	Hinge Arm	316 SS	(4)

Notes: 1. 316 SS - Std Cast Iron Valves, Inconel - Std Carbon Steel & Stainless Steel Valves
 2. PTFE - Std Cast Iron Valves, 316 SS - Std Carbon Steel & Stainless Steel Valves
 3. Parts listed comprise service kit
 4. Parts listed comprise refurbishment kit

Ordering

W 15 A - C 6 V - I

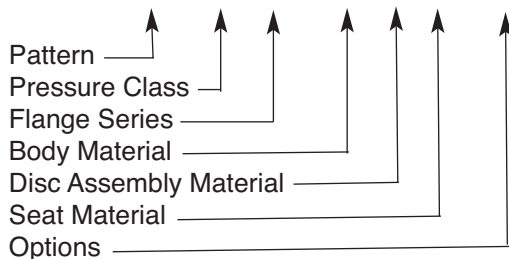

Standard Product Example

W15A-C6V-I

Standard Wafer Pattern, ASME Class 150, Carbon Steel Valve, 316 SS disc assembly Viton Seat, Position Indicator

ULC Approved Model

UI515WM5B

ULC Approved model only
 Wafer pattern, ASME Class 150,
 Cast Iron body, 316 SS disc,
 Viton seat, 250 CWP Rated

Pattern

- W Standard wafer pattern
- A API 594 wafer pattern

Pressure Class

- 12 Class 125
- 15 Class 150
- 30 Class 300
- X Other (please designate)

Flange Series

- A ASME
- D BS10 Table D
- E BS10 Table E
- N BS4504 PN16
- X Other (please designate)

Body Material

- I Cast Iron (ASTMA126 Class B)
- D Ductile Iron
- C Carbon Steel (ASTMA216 WCB)
- 6 Stainless Steel (ASTMA351 CF8M)

Disc Material

- 4 304 SS (ASTM A351 CF8)
- 6 316 SS (ASTM A351 CF8M)

Seat Material

- E EPDM
- N Nitrile
- P PTFE Glass filled
- V Viton
- B Neoprene
- 6 316 SS Weld Overlay
- X Other (please designate)

Extended Stem Options

- B Backflush Lever
- I Position Indicator
- M Microswitch
- S External Spring
- W Lever and Weight
- X Other (please designate)

Flow Characteristics

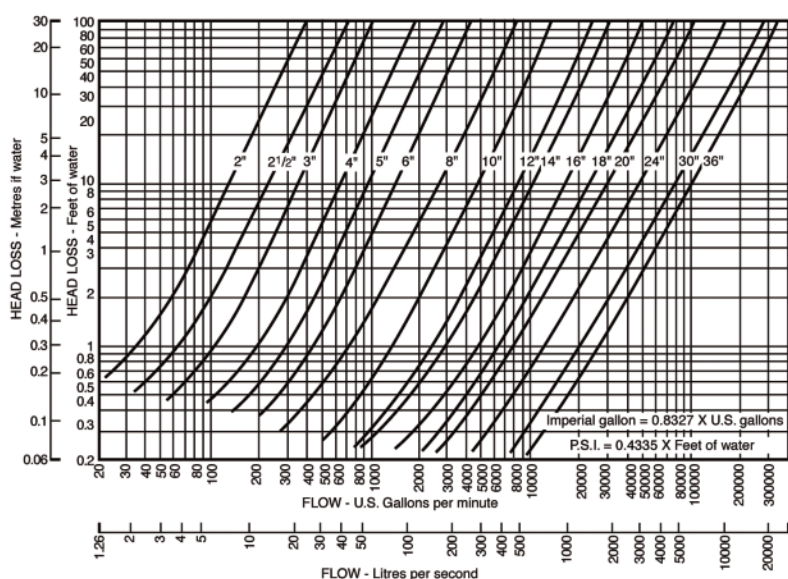

Pressure Drop

Valve Size		Opening Pressure Differential				
in	mm	CV	in WC	mm WC	psi	Bars
2	50	62	5.95	151	0.215	0.015
2.5	65	109	4.50	114	0.163	0.011
3	80	166	3.76	95	0.136	0.009
4	100	318	3.18	81	0.115	0.008
5	125	471	2.58	65	0.093	0.006
6	150	720	2.12	54	0.077	0.005
8	200	1384	2.34	59	0.085	0.006
10	250	2298	2.25	57	0.081	0.006
12	300	4153	2.00	51	0.072	0.005
14	350	4984	1.60	41	0.058	0.004
16	400	8307	1.00	25	0.036	0.002
18	450	11906	0.95	24	0.034	0.002
20	500	16059	0.90	23	0.032	0.002
24	600	22705	0.82	21	0.030	0.002
30	750	47071	0.65	17	0.023	0.002
36	900	53993	0.60	15	0.020	0.001

Seat Temperature Ratings

Seat Material #	Operating Temperature *	
	°F	°C
Stainless Steel	-420 to 600	-250 to 315
Viton	-15 to 400	-26 to 204
Nitrile	-20 to 210	-29 to 100
EPDM	-30 to 300	-35 to 150
Neoprene	-20 to 210	-29 to 100
PTFE	-250 to 450	-156 to 230

* This range of operating temperatures is for general guidance. The range varies with the application and body material.
 # For steam service, resilient seats not permissible. Stainless steel seat recommended.



Installation

The W Series check valve installs between two pipe flanges. The body is flangeless and is centred in line by the surrounding flange bolts. Correct selection of materials and installation will ensure trouble free operation.

Consider the following:

- 1- Check that the pipe flange drilling complies with the valve tag specification.
- 2- Flow direction is indicated by an arrow cast on the valve body.
- 3- On horizontal installations, the valve tag should always be at the top.
- 4- Flow should always be upward on vertical installations.
- 5- The valve reaches fully open position when the clapper contacts the inside diameter of the pipe. If non-standard or lined pipe is used, contact your supplier for recommendations.
- 6- Allow downstream length of straight* pipe equal to two pipe diameter before installing other valves or pipe bends, tees, etc.
- 7- Avoid manifolds, where a pump discharges directly into the valve. A min. installation point of 8 straight* pipe diameter downstream of pumps and 4 straight* pipe diameter downstream of bends and tee's is recommended. For optimal performance, the valve should be located at the point of flow reversal.
- 8- The valve is most suited to SCH-40 pipeline installations. Note SCH-10 installations may cause the disc to over travel on high flow/pressure applications. Consult factory for verification of suitability.
- 9- Bolt may have to be omitted on some stem options.

Note - * The same nominal size as the valve.

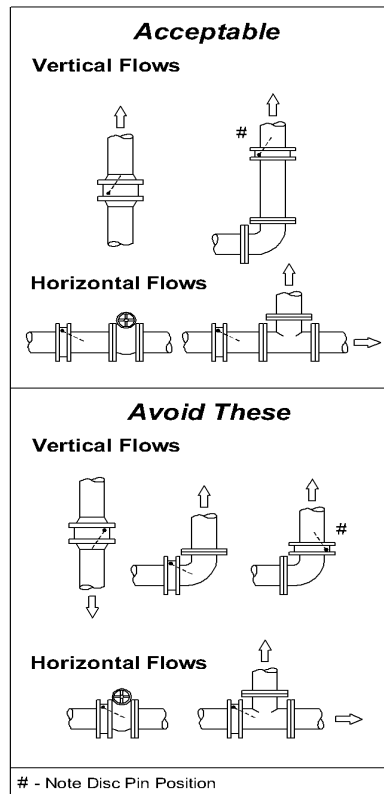

Options Available



With open/shut indicator - See note 9



With counterweight - see note 9

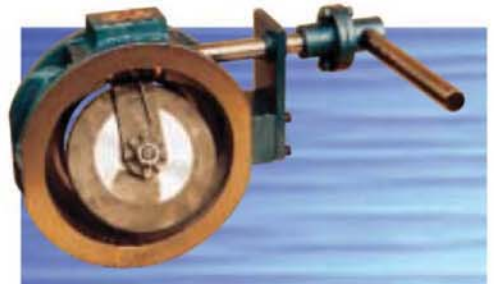

With backflush lever - See note 9

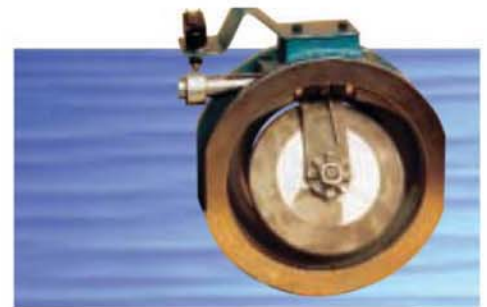

With microswitch - See note 9

Maintenance

Due to the low wearing of working parts and simple robust construction, the valve should not require attention for several years.

However, if the valve is installed on critical applications such as sanitary isolation, it is considered prudent to make yearly inspections.

Valves subject to high frequency of operation may require spring replacement at earlier intervals. This becomes apparent when valve closure is noisy.

Refer to Bill of Materials for service kit options.



M.A. Stewart & Sons Ltd.

Head Office
12900-87th Avenue
Surrey, BC V3W 3H9 Canada
Phone: (604) 594-8431 Fax: (604) 594-4335
Tollfree North America 1-800-594-8431
www.mastewart.com



M. A. Stewart & Sons Ltd.
VALVES AND FITTINGS

Head Office

12900-87th Avenue
Surrey, British Columbia
Canada V3W 3H9
mail to: P.O. 258, Surrey, BC, V3T 4W8
Phone: (604) 594-8431
Toll Free North America: 1-800-594-8431
Fax: (604) 594-4335

Ontario Branch

252 Hunt Street
Ajax, Ontario L1S 1P7
Phone: (905) 683-7303
Fax: (905) 683-9108

Alberta Branch

6125 - 56th Avenue
Edmonton, Alberta T6B 3E2
Phone: (780) 436-9051
Fax: (780) 435-0463
Toll Free in Alberta 1-800-232-7376

Quebec Branch

79H Brunswick Blvd.
Dollard-des-Ormeaux, Que. H9B 2J5
Phone: (514) 421-6311
Fax: (514) 421-6323

Sales Offices

Calgary, Alberta
Phone: (403) 252-7262
Fax: (403) 253-8455

Winnipeg, Manitoba
Phone: (204) 837-5604
Fax: (204) 896-1992

Dartmouth, Nova Scotia
Phone: (905) 683-7303
Fax: (905) 683-9108



B.K. THORPE COMPANY

A MEMBER OF THE M.A. STEWART GROUP 

Long Beach Branch

1811 E. 28th Street
Signal Hill, CA 90755
Phone: (562) 595-1811
Toll Free: 1-888-337-7598
Fax: (562) 426-6016

Bakersfield Branch

5225 Gilmore Ave.
Bakersfield, CA 93308-6302
Phone: (661) 322-1935
Toll Free: 1-877-258-6166
Fax: (661) 322-6719



M. A. Stewart & Sons (USA) Ltd.
VALVES AND FITTINGS

Charlotte Branch

803 Pressley Road, Suite 107
Charlotte, North Carolina, 28217
Phone: (704) 527-0722
Toll Free: 1-866-582-5837
Fax: (704) 527-0791
Toll Free: 1-866-810-9287
