

W-K-M DynaCentric High Performance Butterfly Valves

Valves for Industrial, Process, Oil and Gas, and Pipeline Applications

H
I
G
H

P
E
R
F
O
R
M
A
N
C
E

B
U
T
T
E
R
F
L
Y

V
A
L
V
E
S



The high performance butterfly valve that brings low cost and light weight to high pressure water, oil, steam, gas and slurry applications.

W-K-M DynaCentric butterfly valves satisfy a wide range of industrial applications. Available in carbon steel or stainless steel as well as lug and wafer body styles.

The DynaCentric butterfly valve offers the high performance of ball and gate valves with the low-cost, lightweight benefits of a butterfly valve design. It is ideal for handling water, oil, steam, gas and slurries.

Engineered for heavy-duty, maintenance-free performance in a variety of uses, the W-K-M DynaCentric High Performance butterfly valve is most commonly selected for the following applications:

- Chemical and petrochemical processing
- Utilities
- Pulp and paper
- Oil and gas production
- Fuel handling systems
- Air conditioning and refrigeration
- Marine

The W-K-M DynaCentric Advantage...

T
H
E
W
K
M
A
D
V
A
N
T
A
G
E

Two Body Styles

Flangeless wafer and threaded lug styles are available.

Heavy-duty Disc

Designed to withstand the higher stresses associated with high pressure applications. Wide disc edge provides greater sealing area.

Thrust Bearing/Disc Spacer

A corrosion resistant, single component thrust bearing/disc spacer reduces body wear and assures positive centering of disc in the valve bore.

Internal Stop

Prevents disc over-travel and seat damage caused by disc over-travel. Assures proper disc alignment in closed position.

Disc Design Reduces Seat Wear

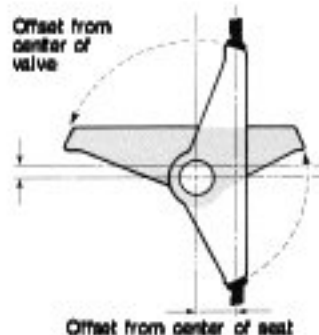

Precision machined from carbon or alloy steels, the rugged valve disc is designed for gradual engagement into seat to prevent pinching or cutting. Eccentric positioning of stem allows disc to swing free of seat in open position, reducing operating torque and wear. Special surface coatings such as stellite overlay are available for critical or severe service conditions.

Positively Retained Stem Prevents Blowouts

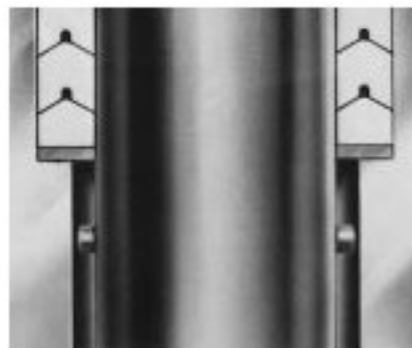

The tamper-proof design not only meets but exceeds the requirements of ANSI B16.34. The disc, disc pins and stem design meet ASME requirements for maximum torsional and bending stress. Additional blowout prevention is provided by stem retainer pins inserted in the stem below the stuffing box (shown above).

The Primary Advantage: Unique, Proven Seat Designs Excel in Critical Services

Three Seat Designs



The standard polymer seat (SO2) is bi-directional with an extended pressure responsive sealing lip. The SO2 seat design is capable of drop tight sealing to 740 PSI.

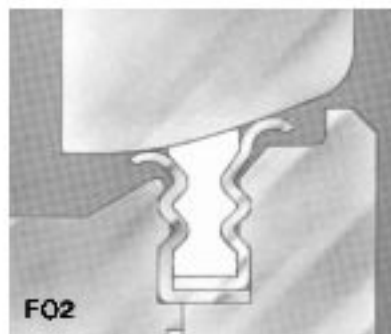

The patented, fire-tested, bi-directional metallic seats with TFE seat insert (FO2) provide a metal-to-metal pressure responsive triple seal. DynaCentric valves with the FO2 seat design and high temperature seals have been fire-tested and are qualified to meet the stringent requirements of API 607, 4th edition. This unique design provides fire-test capabilities regardless of flow direction. The FO2 seat design is capable of drop tight sealing to 1480 PSI.



Valves constructed of 316 stainless steel and assembled with the proper trims and Ni-Cr Alloy (UNS No. 6625) seats (MO3) are capable of handling temperatures to 1000°F. Metal seats of 316SS (MO1) are suitable for temperatures to 750°F.

Deep Stuffing Box For Extended Life

Deep stuffing box design includes stainless steel fasteners as standard and is available with TFE chevron or high-temperature compression packing for long life and positive stem seal. Live loaded packing assemblies and double stuffing box with purge/monitor port available upon special request for critical applications.

Valves are Readily Automated



New Model MB-1 (Lug)



MB-1 Model
Available now 2-1/2" - 6"
150 and 300
(8"-12" 150-300 in
development)

Model MB-1 (Wafer)

MB-1 Features:

- Inset seat retainer.
- Uninterrupted sealing surface.
- Contoured body for lighter weight.
- Integrally cast internal stop.

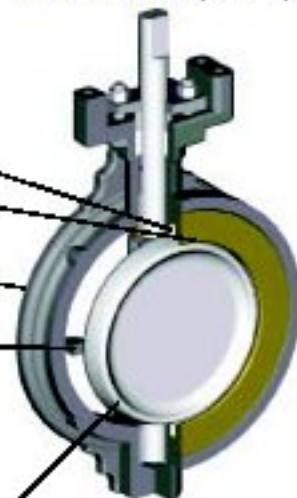

Features Common to Both Models:

- Heavy-duty eccentric disc with wide sealing area.

Model MA-1 (Wafer)

Model MA-1 (Lug)



SD1366

MA-1 Model
3"-12" Class 600
8"-12" Class 150 and 300
(30" Class 150 in development)

- Stainless steel fasteners.
- Deep stuffing box.
- Positively retained stems.
- Close tolerance guides assure proper valve/flange alignment.
- Standard stems are 17-4 PH Stainless Steel, condition H1150 double-aged.
- Thrust bearing reduces body wear.
- Low friction, high load upper and lower stem journal bearings lower operating torque.
- Stem disc springs allow thermal expansion and provide constant grounding.



SD10255

W-K-M

Special Service Valves

High Temperature

DynaCentric valves for high temperature service are equipped with a 316 stainless steel seat (MO1), 316 stainless steel stem bearings and high temperature seals. This seat/seal combination is rated up to 750°F in carbon steel bodies. Ni-Cr Alloy (UNS No. 6625) seats (MO3) and stainless steel bodies can be utilized up to 1000°F. Leakage rates for metal seated valves can be provided within the service limits of ANSI/FCI 70-2 Class V on request. Standard leakage rate of metal seated valves is less than .005ml/PSI/NPS. DynaCentric valves furnished with this seat perform well in steam, hot oil and heat transfer fluids.

Vacuum Service

The drop-tight sealing capabilities of DynaCentric valves make them an excellent selection for vacuum service. SO1, SO2, and FO2 seat-seal codes are suitable for vacuum service to 20 microns absolute. Inverted packing or purged stuffing box configuration is available on request.

Sour Oil and Gas Service

DynaCentric valves with sour gas trims are available for H₂S Service in accordance with NACE MR-01-75, latest issue.

Low Temperature Service

DynaCentric valves for temperatures to -50°F are available in both 316 stainless steel construction and low temperature carbon steel.

Oxygen Service

DynaCentric valves provide the positive shut-off and tight sealing necessary for gaseous oxygen service. Due to the risk of explosion and fire inherent in such service, positive grounding for the disc and stem with the Belleville disc springs is standard. Positive safeguards have been established in order to conform to the requirement that valves for oxygen service must be completely free of oil, grease, combustible material, slag, metal shavings, paint, rust or various fibers. All parts are cleaned of contaminants with solvent and inspected under black light. After assembly and testing with nitrogen, each valve is individually tagged and sealed in a polyethylene bag. Valves for such service may be supplied in any materials, but 316 stainless steel or Ni-Cu Alloy (UNS No. 5500) are recommended.

Steam Service

DynaCentric valves are ideally suited for applications in steam service. Reinforced TFE seats (SO2) with high temperature packing will handle steam to 100 psig saturation pressure. When fitted with 316 stainless steel seats with reinforced TFE inserts (FO2), the DynaCentric valve is suitable for steam to 125 psig saturation pressures. The combination of rotary operation, streamlined flow and positive shut-off can result in years of maintenance-free service without the seizures on cool-down, flashing or stem leakage associated with conventional gate or globe valves.

Enhanced Fugitive Mission Control

The valve stuffing box can be modified for live loaded packing assemblies, or include a double stuffing box with purge/monitor port.

PRODUCT PROFILE

SIZES

2-1/2" to 24"

WORKING PRESSURE

ANSI Class 150-300, 2-1/2"-24"
ANSI Class 600, 3"-12"

OPERATING TEMPERATURES

Up to 1000°F (538°C)

BODY STYLES

Flangeless Wafer, Threaded Lug

STANDARD MATERIALS

Body - Carbon Steel, Stainless Steel
Stem - 17-4 Stainless Steel
Seat - SO2 - RTFE
FO2 - Fire-safe
MO1/MO3 - Metal Seat

OPTIONAL MATERIALS

Seat/seal trims are available for hundreds of different ladings.